

Chapter 7: UV Spectroscopy

- UV & electronic transitions
- Usable ranges & observations
- Selection rules
- Band Structure
- Instrumentation & Spectra
- Beer-Lambert Law
- Application of UV-spec



CHMBD 449 – Organic Spectral Analysis

UV Spectroscopy

I. Introduction

A. UV radiation and Electronic Excitations

1. The difference in energy between molecular bonding, non-bonding and anti-bonding orbitals ranges from 125-650 kJ/mole
2. This energy corresponds to EM radiation in the ultraviolet (UV) region, 100-350 nm, and visible (VIS) regions 350-700 nm of the spectrum
3. For comparison, recall the EM spectrum:

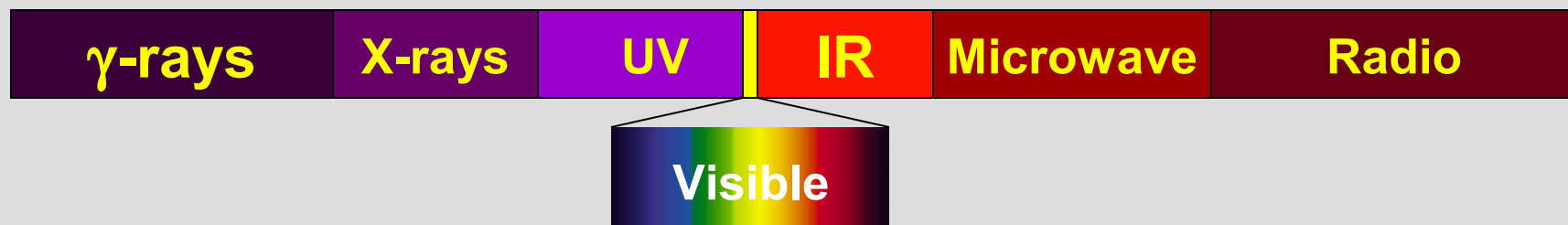

4. Using IR we observed vibrational transitions with energies of 8-40 kJ/mol at wavelengths of 2500-15,000 nm
5. For purposes of our discussion, we will refer to UV and VIS spectroscopy as UV

UV Spectroscopy

I. Introduction

B. The Spectroscopic Process

1. In UV spectroscopy, the sample is irradiated with the broad spectrum of the UV radiation
2. If a particular electronic transition matches the energy of a certain band of UV, it will be absorbed
3. The remaining UV light passes through the sample and is observed
4. From this residual radiation a spectrum is obtained with “gaps” at these discrete energies – this is called an *absorption spectrum*

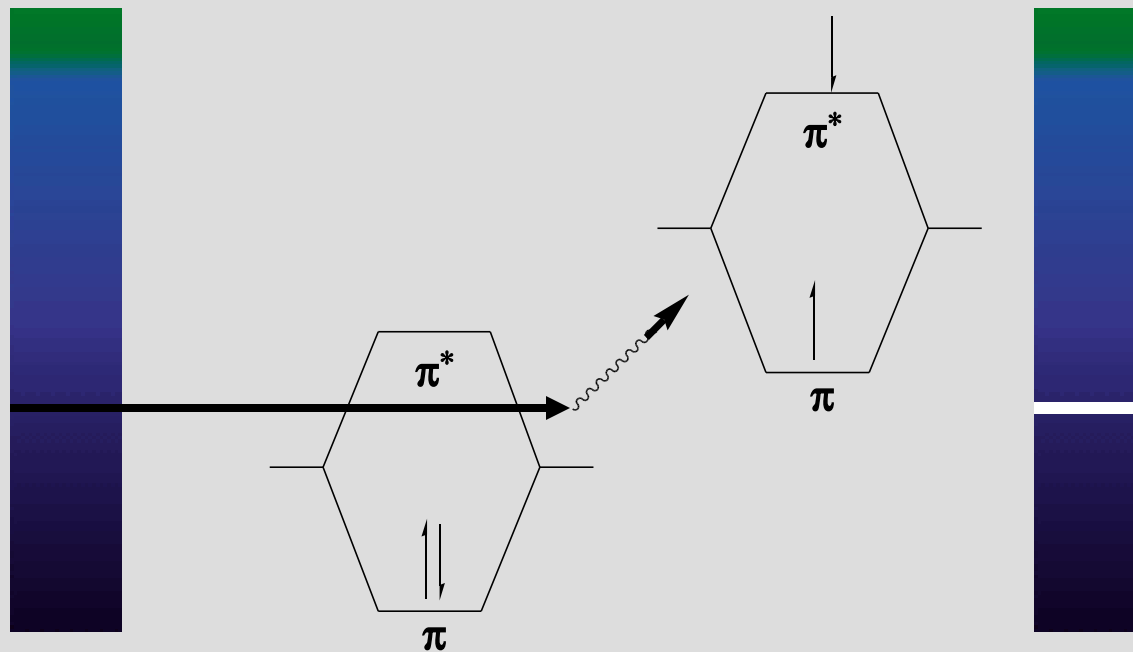

I. Introduction

C. Observed electronic transitions

1. The lowest energy transition (and most often obs. by UV) is typically that of an electron in the Highest Occupied Molecular Orbital (HOMO) to the Lowest Unoccupied Molecular Orbital (LUMO)
2. For any bond (pair of electrons) in a molecule, the molecular orbitals are a mixture of the two contributing atomic orbitals; for every bonding orbital “created” from this mixing (σ , π), there is a corresponding anti-bonding orbital of symmetrically higher energy (σ^* , π^*)
3. The lowest energy occupied orbitals are typically the σ ; likewise, the corresponding anti-bonding σ^* orbital is of the highest energy
4. π -orbitals are of somewhat higher energy, and their complementary anti-bonding orbital somewhat lower in energy than σ^* .
5. Unshared pairs lie at the energy of the original atomic orbital, most often this energy is higher than π or σ (since no bond is formed, there is no benefit in energy)

UV Spectroscopy

- I. Introduction
 - C. Observed electronic transitions
 - 6. Here is a graphical representation

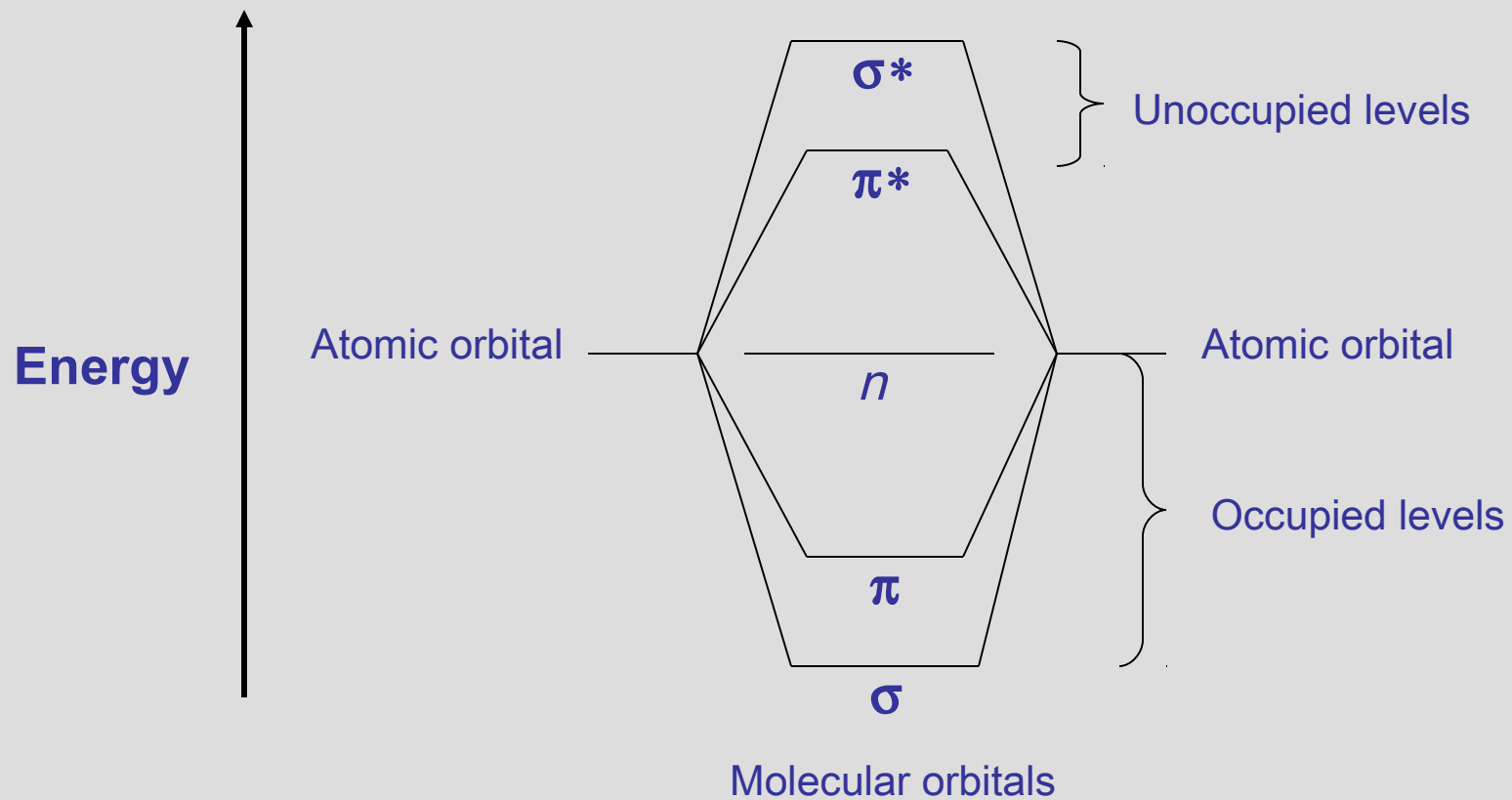

UV Spectroscopy

I. Introduction

C. Observed electronic transitions

7. From the molecular orbital diagram, there are several possible electronic transitions that can occur, each of a different relative energy:

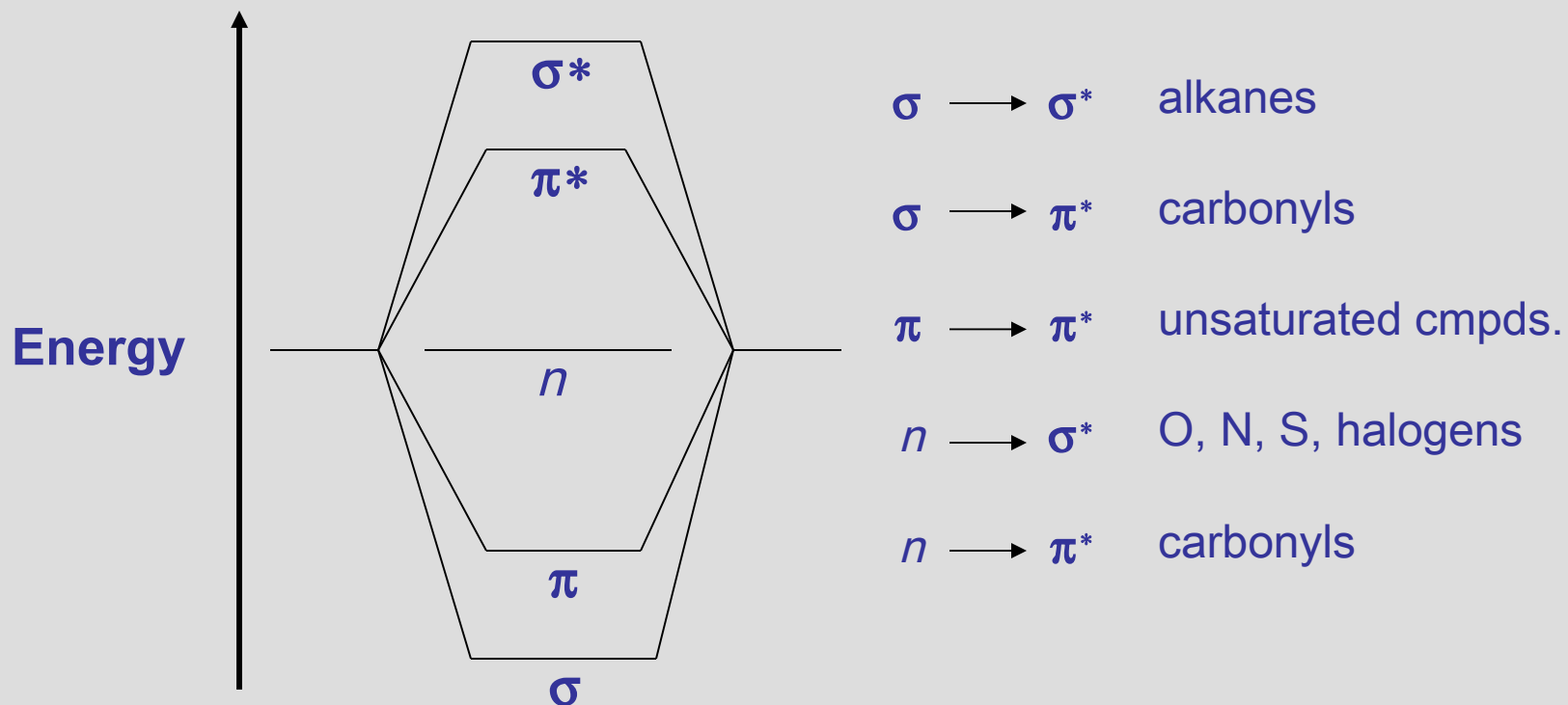

UV Spectroscopy

I. Introduction

C. Observed electronic transitions

7. Although the UV spectrum extends below 100 nm (high energy), oxygen in the atmosphere is not transparent below 200 nm
8. Special equipment to study *vacuum* or *far UV* is required
9. Routine organic UV spectra are typically collected from 200-700 nm
10. This limits the transitions that can be observed:

$\sigma \longrightarrow \sigma^*$ alkanes 150 nm

$\sigma \longrightarrow \pi^*$ carbonyls 170 nm

$\pi \longrightarrow \pi^*$ unsaturated cmpds. 180 nm \checkmark - if conjugated!

$n \longrightarrow \sigma^*$ O, N, S, halogens 190 nm

$n \longrightarrow \pi^*$ carbonyls 300 nm \checkmark

I. Introduction

D. Selection Rules

1. Not all transitions that are possible are observed
2. For an electron to transition, certain quantum mechanical constraints apply – these are called “**selection rules**”
3. For example, an electron cannot change its spin quantum number during a transition – these are “**forbidden**”

Other examples include:

- the number of electrons that can be excited at one time
 - symmetry properties of the molecule
 - symmetry of the electronic states
2. To further complicate matters, “forbidden” transitions are sometimes observed (albeit at low intensity) due to other factors

I. Introduction

E. Band Structure

1. Unlike IR (or later NMR), where there may be upwards of 5 or more resolvable peaks from which to elucidate structural information, UV tends to give wide, overlapping bands
2. It would seem that since the electronic energy levels of a pure sample of molecules would be quantized, fine, discrete bands would be observed – for atomic spectra, this is the case
3. In molecules, when a bulk sample of molecules is observed, not all bonds (read – pairs of electrons) are in the same vibrational or rotational energy states
4. This effect will impact the wavelength at which a transition is observed – very similar to the effect of H-bonding on the O-H vibrational energy levels in neat samples

UV Spectroscopy

I. Introduction

E. Band Structure

1. When these energy levels are superimposed, the effect can be readily explained – any transition has the possibility of being observed

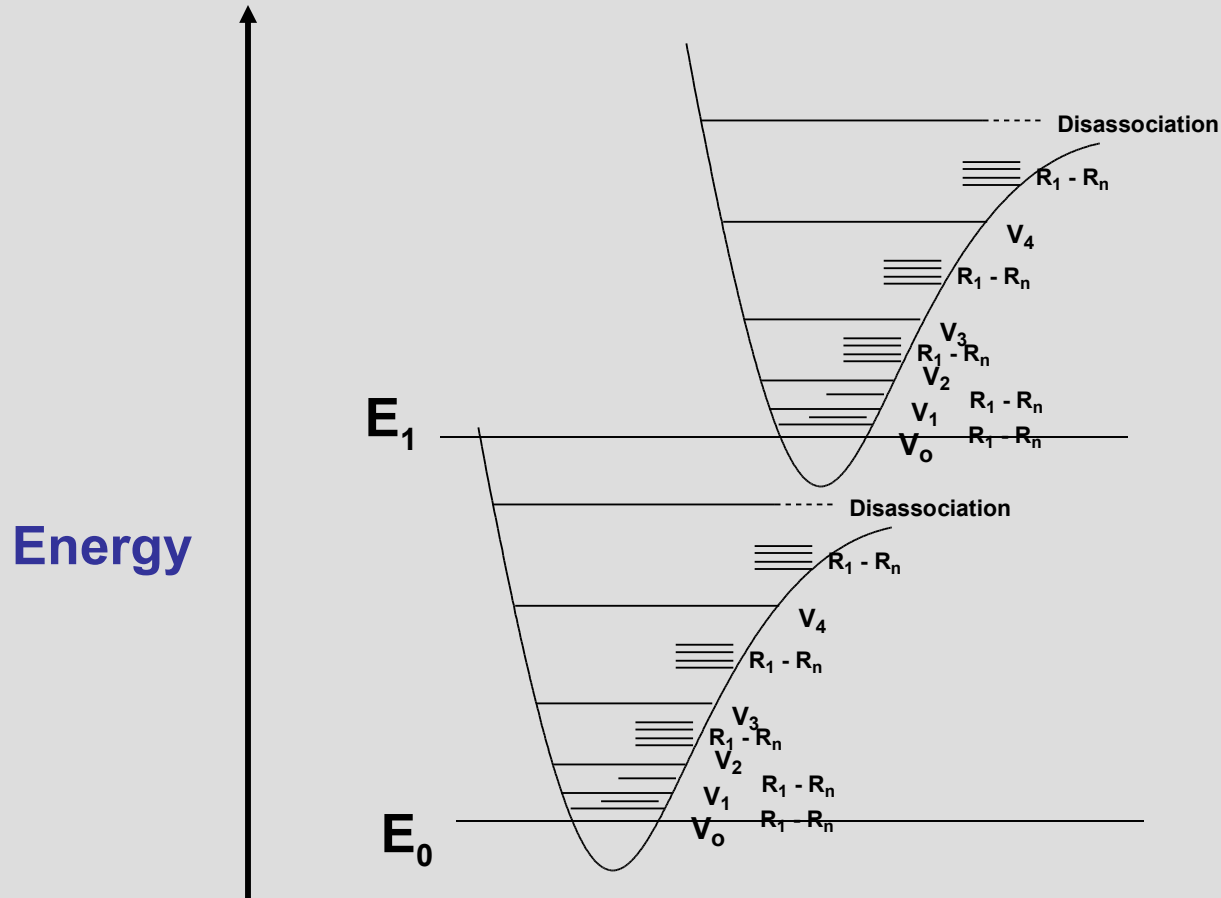

UV Spectroscopy

II. Instrumentation and Spectra

A. Instrumentation

1. The construction of a traditional UV-VIS spectrometer is very similar to an IR, as similar functions – sample handling, irradiation, detection and output are required
2. Here is a simple schematic that covers most modern UV spectrometers:

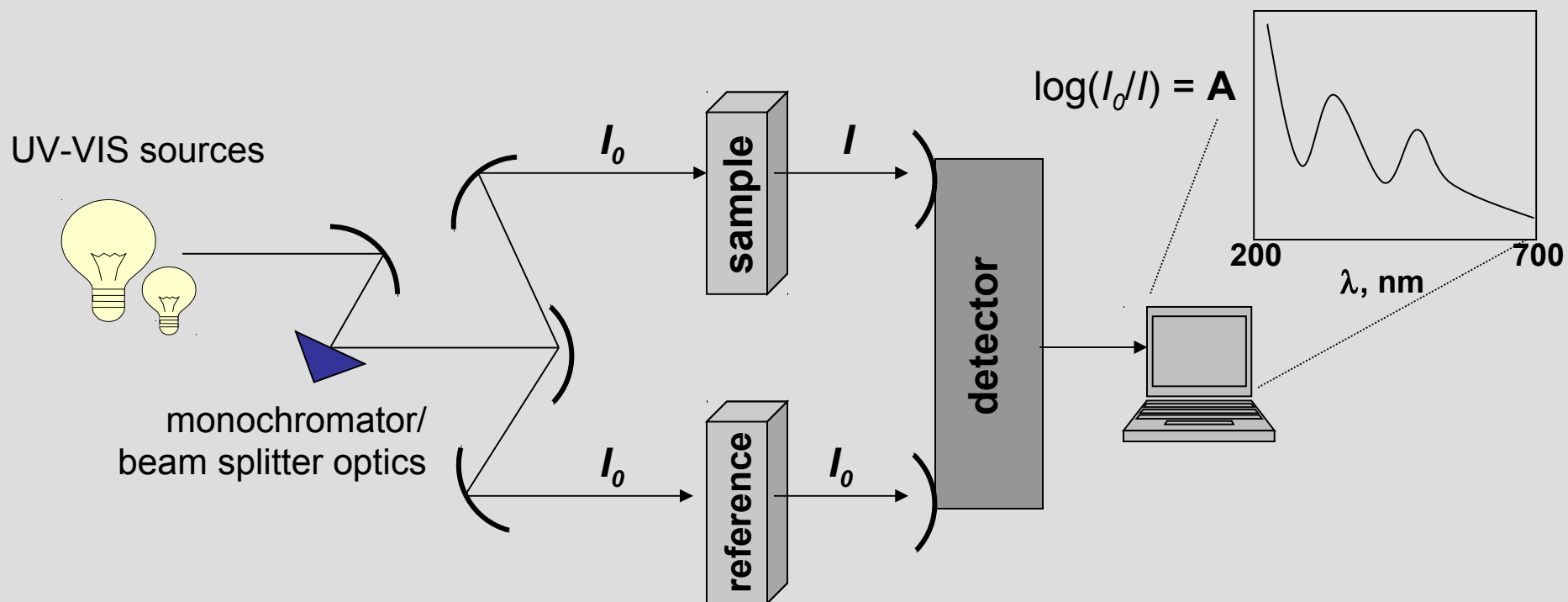

II. Instrumentation and Spectra

A. Instrumentation

3. Two sources are required to scan the entire UV-VIS band:
 - Deuterium lamp – covers the UV – 200-330
 - Tungsten lamp – covers 330-700

3. As with the dispersive IR, the lamps illuminate the entire band of UV or visible light; the monochromator (grating or prism) gradually changes the small bands of radiation sent to the beam splitter

4. The beam splitter sends a separate band to a cell containing the sample solution and a reference solution

5. The detector measures the difference between the transmitted light through the sample (I) vs. the incident light (I_0) and sends this information to the recorder

II. Instrumentation and Spectra

A. Instrumentation

7. As with dispersive IR, time is required to cover the entire UV-VIS band due to the mechanism of changing wavelengths
8. A recent improvement is the diode-array spectrophotometer - here a prism (dispersion device) breaks apart the full spectrum transmitted through the sample
9. Each individual band of UV is detected by a individual diodes on a silicon wafer simultaneously – the obvious limitation is the size of the diode, so some loss of resolution over traditional instruments is observed

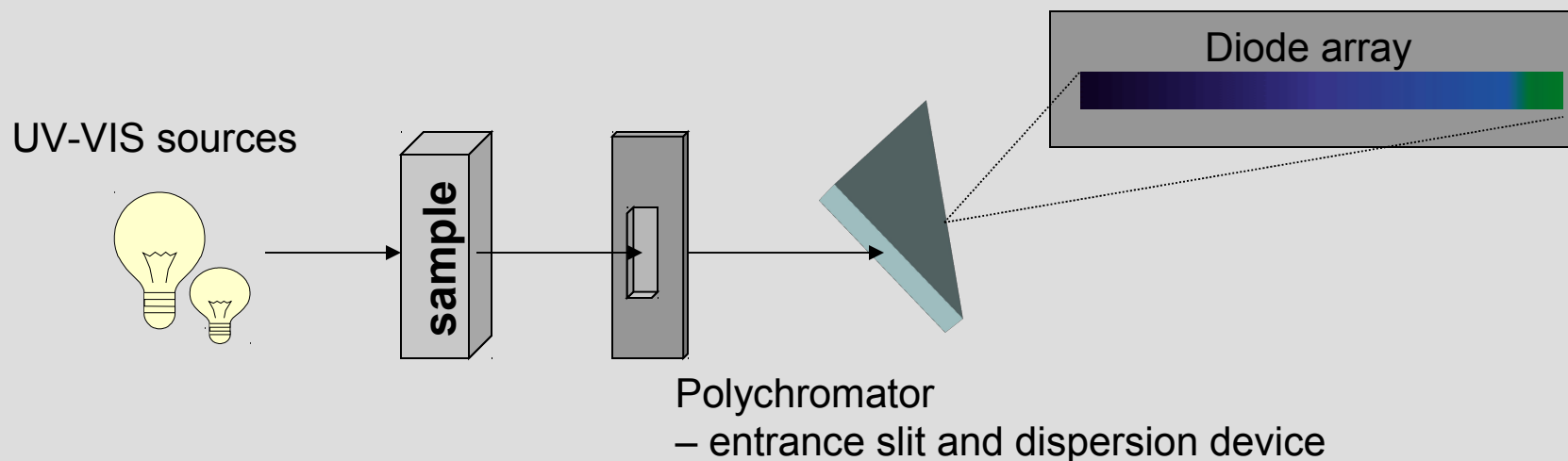

II. Instrumentation and Spectra

A. Instrumentation – Sample Handling

1. Virtually all UV spectra are recorded solution-phase
2. Cells can be made of plastic, glass or quartz
3. Only quartz is transparent in the full 200-700 nm range; plastic and glass are only suitable for visible spectra
4. Concentration (we will cover shortly) is empirically determined

A typical sample cell (commonly called a *cuve*t):



II. Instrumentation and Spectra

A. Instrumentation – Sample Handling

5. Solvents must be transparent in the region to be observed; the wavelength where a solvent is no longer transparent is referred to as the **cutoff**
6. Since spectra are only obtained up to 200 nm, solvents typically only need to lack conjugated π systems or carbonyls

Common solvents and cutoffs:

acetonitrile	190	
chloroform	240	
cyclohexane	195	
1,4-dioxane	215	
95% ethanol	205	
<i>n</i> -hexane	201	
methanol	205	
isooctane		195
water	190	

II. Instrumentation and Spectra

A. Instrumentation – Sample Handling

7. Additionally solvents must preserve the fine structure (where it is actually observed in UV!) where possible
8. H-bonding further complicates the effect of vibrational and rotational energy levels on electronic transitions, dipole-dipole interacts less so
9. The more non-polar the solvent, the better (this is not always possible)

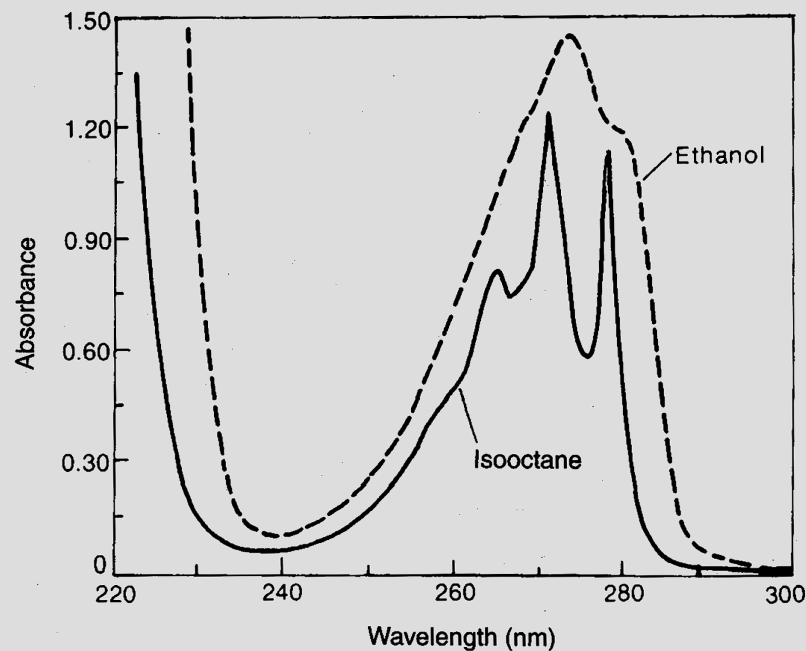

II. Instrumentation and Spectra

C. The Spectrum

1. The x-axis of the spectrum is in wavelength; 200-350 nm for UV, 200-700 for UV-VIS determinations
2. Due to the lack of any fine structure, spectra are rarely shown in their raw form, rather, the peak maxima are simply reported as a numerical list of “lambda max” values or λ_{\max}

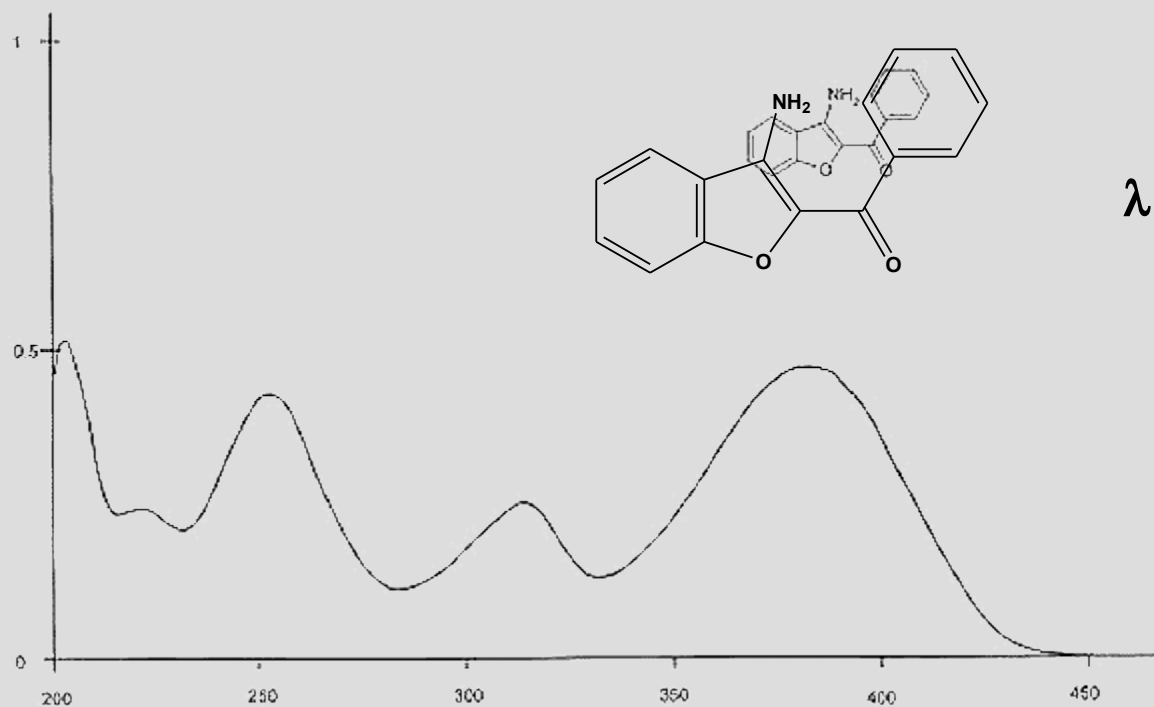

$\lambda_{\max} =$
206 nm
252
317
376

II. Instrumentation and Spectra

C. The Spectrum

1. The y-axis of the spectrum is in absorbance, A
2. From the spectrometers point of view, absorbance is the inverse of transmittance: $A = \log_{10} (I_0/I)$
3. From an experimental point of view, three other considerations must be made:
 - i. a longer *path length*, l through the sample will cause more UV light to be absorbed – linear effect
 - ii. the greater the *concentration*, c of the sample, the more UV light will be absorbed – linear effect
 - iii. some electronic transitions are more effective at the absorption of photon than others – *molar absorptivity*, ϵ
this may vary by orders of magnitude...

II. Instrumentation and Spectra

C. The Spectrum

4. These effects are combined into the Beer-Lambert Law: $A = \epsilon c l$
 - i. for most UV spectrometers, l would remain constant (standard cells are typically 1 cm in path length)
 - ii. concentration is typically varied depending on the strength of absorption observed or expected – typically dilute – sub .001 M
 - iii. molar absorptivities vary by orders of magnitude:
 - values of 10^4 - 10^6 are termed *high intensity absorptions*
 - values of 10^3 - 10^4 are termed *low intensity absorptions*
 - values of 0 to 10^3 are the absorptions of *forbidden transitions*

A is unitless, so the units for ϵ are $\text{cm}^{-1} \cdot \text{M}^{-1}$ and are rarely expressed

5. Since path length and concentration effects can be easily factored out, absorbance simply becomes proportional to ϵ , and the y-axis is expressed as ϵ directly or as the logarithm of ϵ

II. Instrumentation and Spectra

D. Practical application of UV spectroscopy

1. UV was the first organic spectral method, however, it is rarely used as a primary method for structure determination
2. It is most useful in combination with NMR and IR data to elucidate unique electronic features that may be ambiguous in those methods
3. It can be used to assay (via λ_{max} and molar absorptivity) the proper irradiation wavelengths for photochemical experiments, or the design of UV resistant paints and coatings
4. The most ubiquitous use of UV is as a detection device for HPLC; since UV is utilized for solution phase samples vs. a reference solvent this is easily incorporated into LC design

UV is to HPLC what mass spectrometry (MS) will be to GC

III. Chromophores

A. Definition

1. Remember the electrons present in organic molecules are involved in covalent bonds or lone pairs of electrons on atoms such as O or N
2. Since similar functional groups will have electrons capable of discrete classes of transitions, the characteristic energy of these energies is more representative of the functional group than the electrons themselves
3. A functional group capable of having characteristic electronic transitions is called a **chromophore** (*color loving*)
4. Structural or electronic changes in the chromophore can be quantified and used to predict shifts in the observed electronic transitions

III. Chromophores

B. Organic Chromophores

1. **Alkanes** – only possess σ -bonds and no lone pairs of electrons, so only the high energy $\sigma \rightarrow \sigma^*$ transition is observed in the far UV

This transition is destructive to the molecule, causing cleavage of the σ -bond

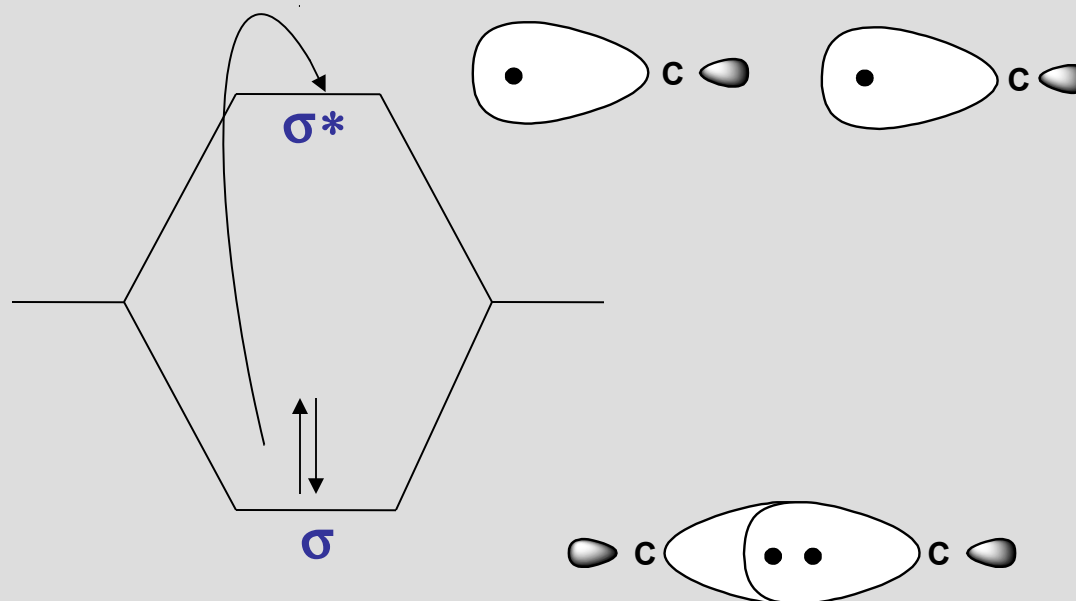

III. Chromophores

B. Organic Chromophores

1. Alcohols, ethers, amines and sulfur compounds – in the cases of simple, aliphatic examples of these compounds the $n \rightarrow \sigma^*$ is the most often observed transition; like the alkane $\sigma \rightarrow \sigma^*$ it is most often at shorter λ than 200 nm

Note how this transition occurs from the HOMO to the LUMO

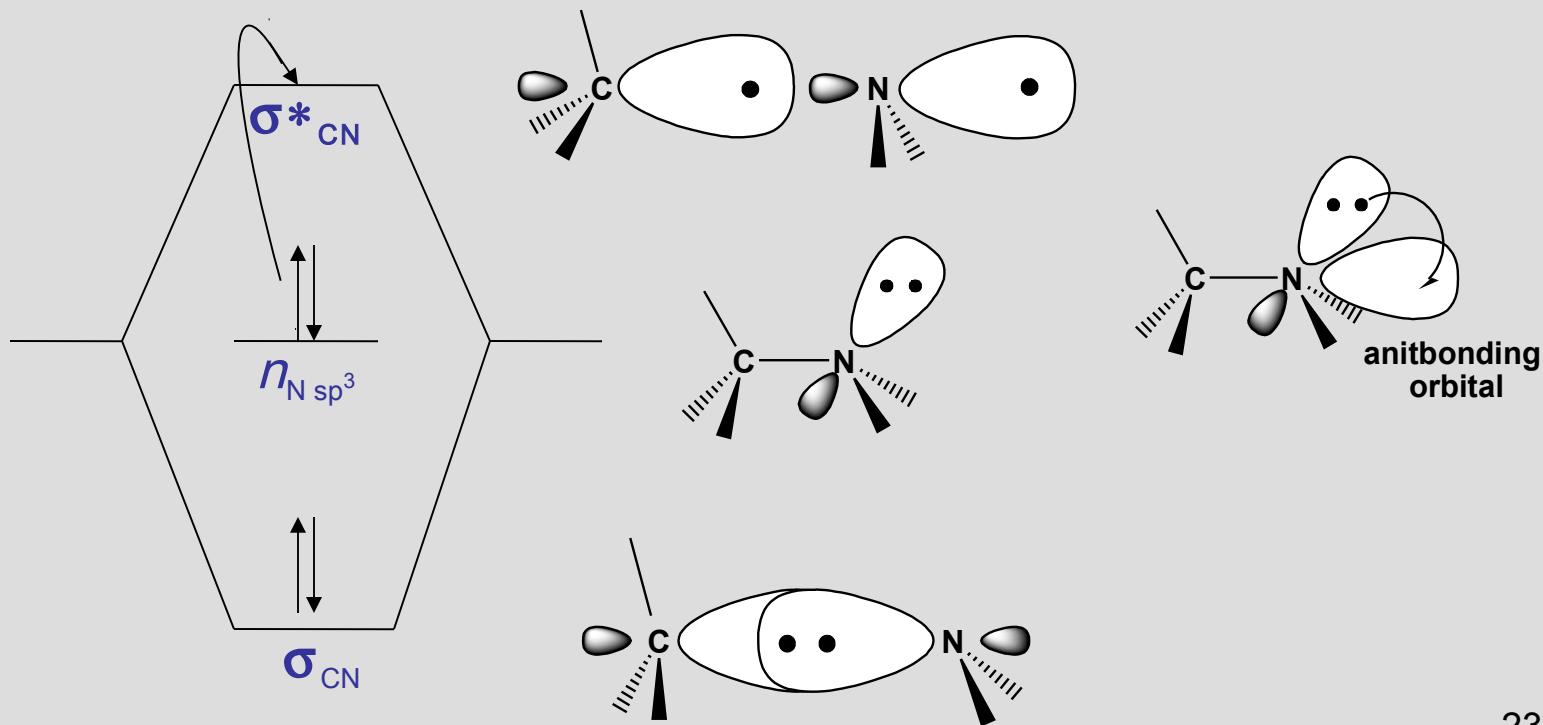

III. Chromophores

B. Organic Chromophores

3. **Alkenes and Alkynes** – in the case of isolated examples of these compounds the $\pi \rightarrow \pi^*$ is observed at 175 and 170 nm, respectively

Even though this transition is of lower energy than $\sigma \rightarrow \sigma^*$, it is still in the far UV – however, the transition energy is sensitive to substitution

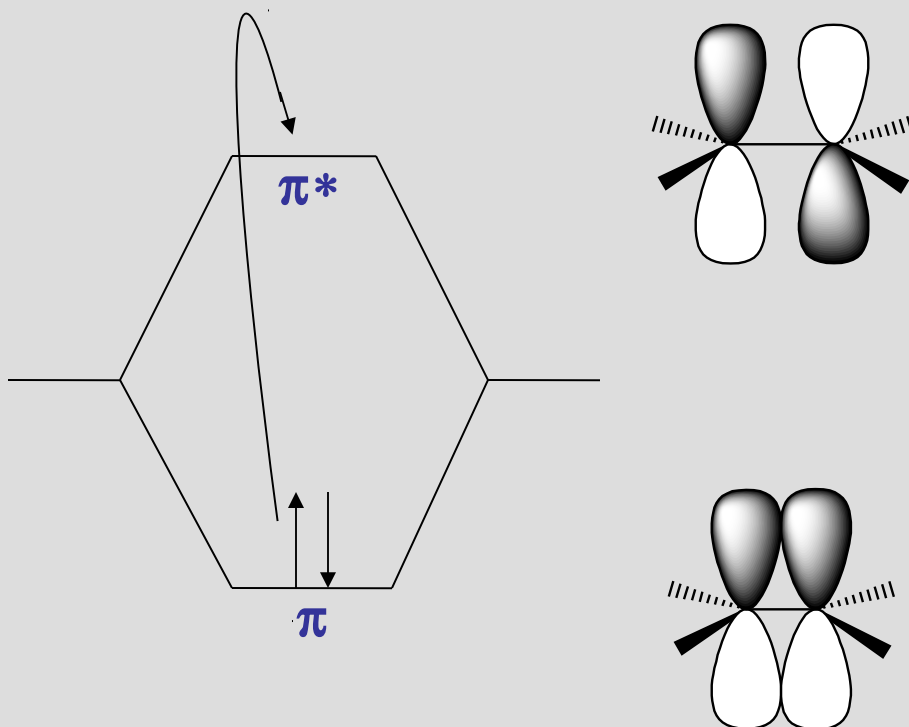

III. Chromophores

B. Organic Chromophores

4. **Carbonyls** – unsaturated systems incorporating N or O can undergo $n \rightarrow \pi^*$ transitions (~ 285 nm) in addition to $\pi \rightarrow \pi^*$

Despite the fact this transition is forbidden by the selection rules ($\epsilon = 15$), it is the most often observed and studied transition for carbonyls

This transition is also sensitive to substituents on the carbonyl

Similar to alkenes and alkynes, non-substituted carbonyls undergo the $\pi \rightarrow \pi^*$ transition in the vacuum UV (188 nm, $\epsilon = 900$); sensitive to substitution effects

III. Chromophores

B. Organic Chromophores

4. **Carbonyls** – $n \rightarrow \pi^*$ transitions (~ 285 nm); $\pi \rightarrow \pi^*$ (188 nm)

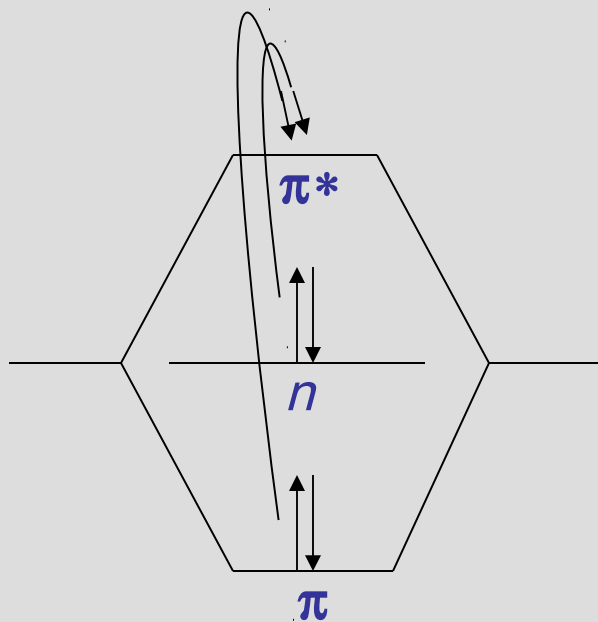

σ_{CO} transitions omitted for clarity

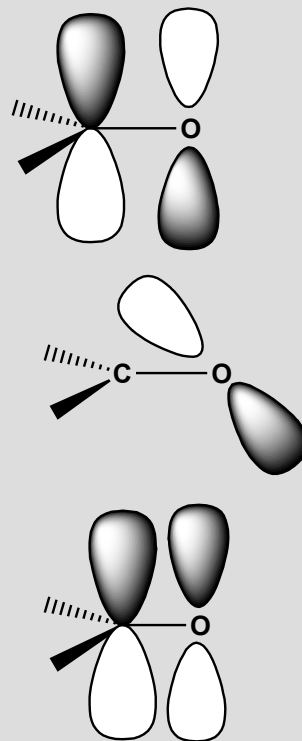

It has been determined from spectral studies, that carbonyl oxygen more approximates sp rather than sp^2 !

III. Chromophores

A. Substituent Effects

General – from our brief study of these general chromophores, only the weak $n \rightarrow \pi^*$ transition occurs in the routinely observed UV

The attachment of substituent groups (other than H) can shift the energy of the transition

Substituents that increase the intensity and often wavelength of an absorption are called *auxochromes*

Common auxochromes include alkyl, hydroxyl, alkoxy and amino groups and the halogens

III. Chromophores

A. Substituent Effects

General – Substituents may have any of four effects on a chromophore

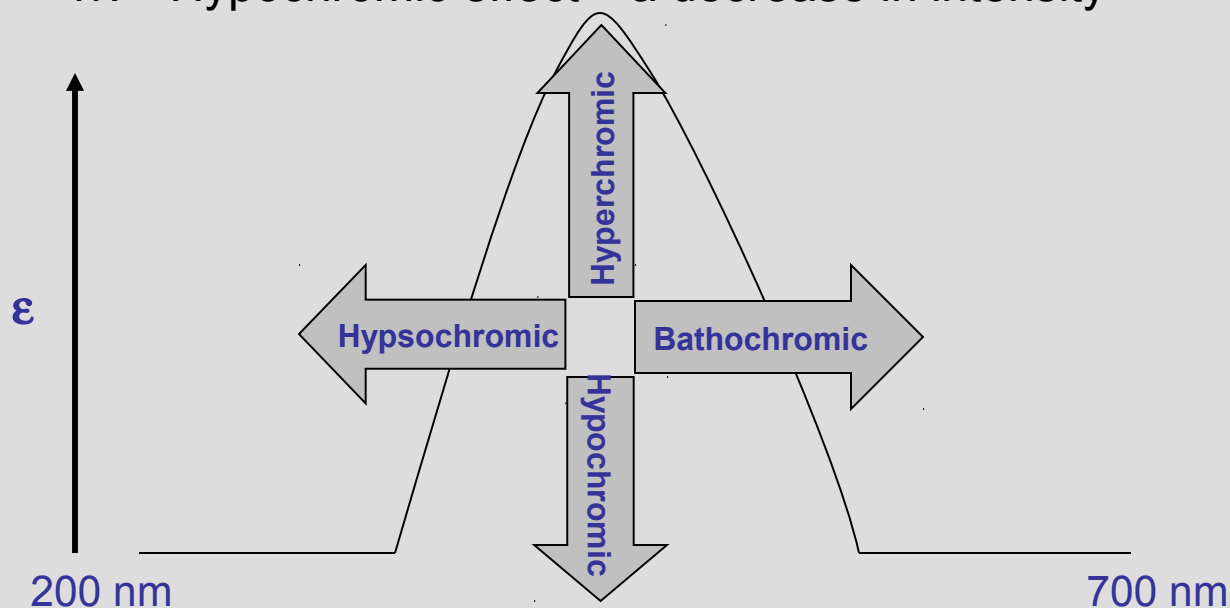

- i. **Bathochromic shift** (red shift) – a shift to longer λ ; lower energy
- ii. **Hypsochromic shift** (blue shift) – shift to shorter λ ; higher energy
- iii. **Hyperchromic effect** – an increase in intensity
- iv. **Hypochromic effect** – a decrease in intensity



III. Chromophores

A. Substituent Effects

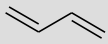
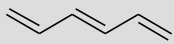
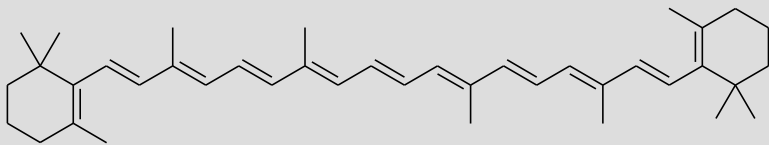
1. **Conjugation** – most efficient means of bringing about a bathochromic and hyperchromic shift of an unsaturated chromophore:

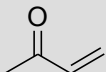
	λ_{max} nm	ϵ
$\text{H}_2\text{C}=\text{CH}_2$	175	15,000
	217	21,000
	258	35,000
 β-carotene	465	125,000
	$n \rightarrow \pi^*$ 280 $\pi \rightarrow \pi^*$ 189	12 900
	$n \rightarrow \pi^*$ 280 $\pi \rightarrow \pi^*$ 213	27 7,100

III. Chromophores

A. Substituent Effects

1. Conjugation – Alkenes

The observed shifts from conjugation imply that an increase in conjugation decreases the energy required for electronic excitation

From molecular orbital (MO) theory two atomic p orbitals, ϕ_1 and ϕ_2 from two sp^2 hybrid carbons combine to form two MOs Ψ_1 and Ψ_2^* in ethylene

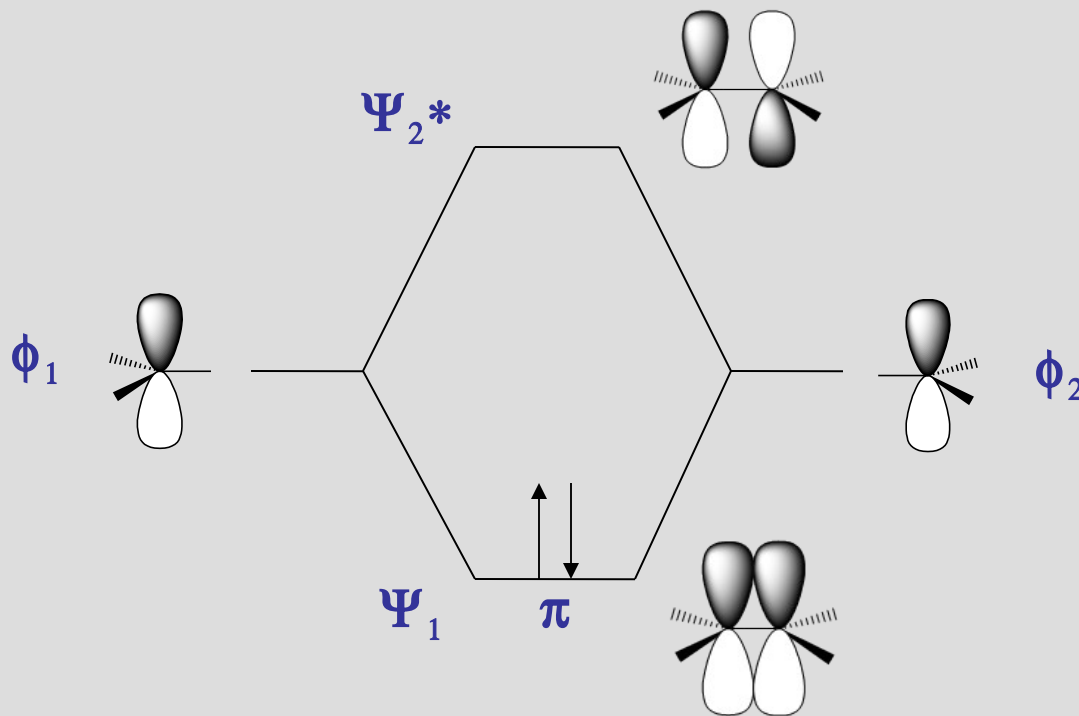

III. Chromophores

A. Substituent Effects

2. Conjugation – Alkenes

When we consider butadiene, we are now mixing 4 p orbitals giving 4 MOs of an energetically symmetrical distribution compared to ethylene

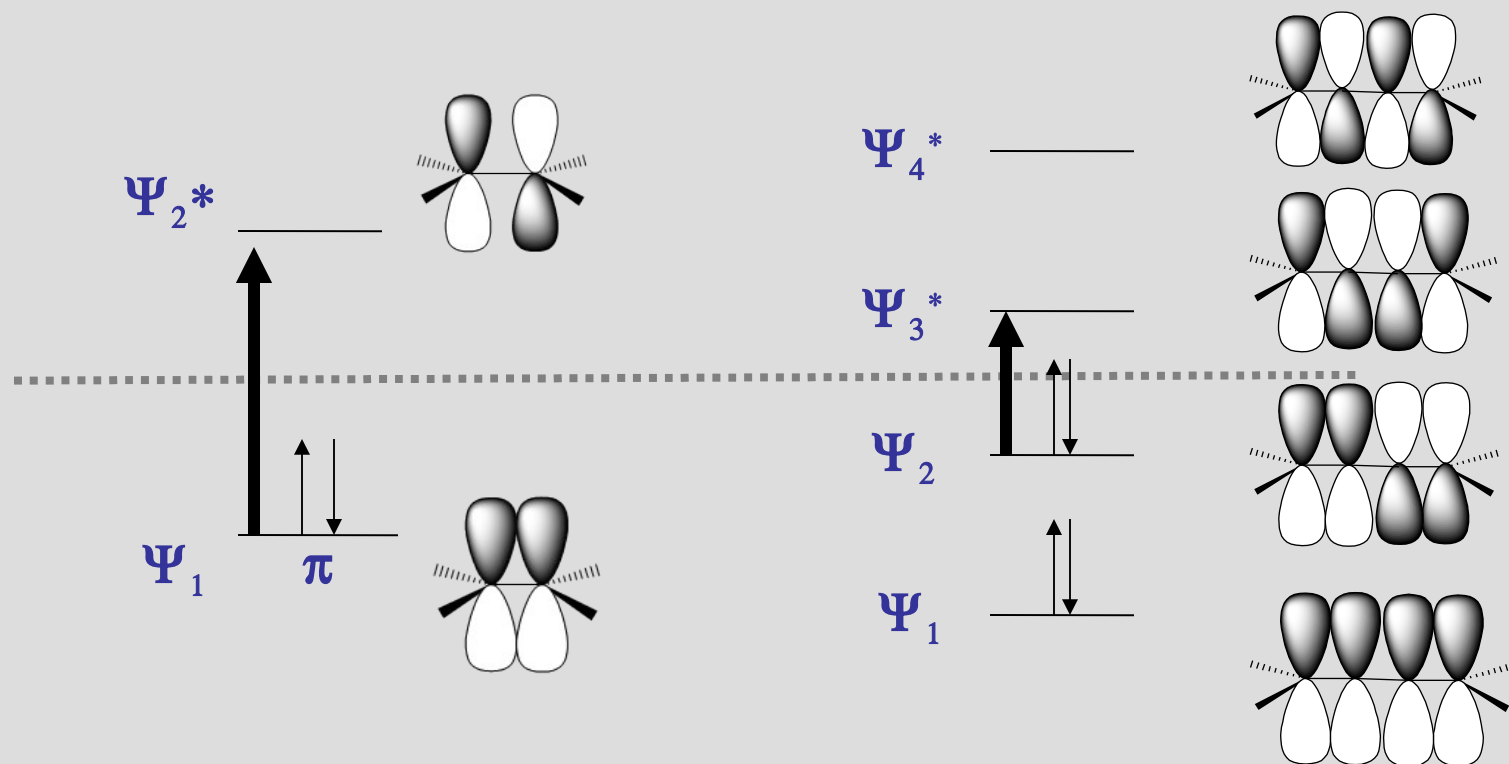

ΔE for the HOMO \rightarrow LUMO transition is **reduced**

III. Chromophores

A. Substituent Effects

2. Conjugation – Alkenes

Extending this effect out to longer conjugated systems the energy gap becomes progressively smaller:

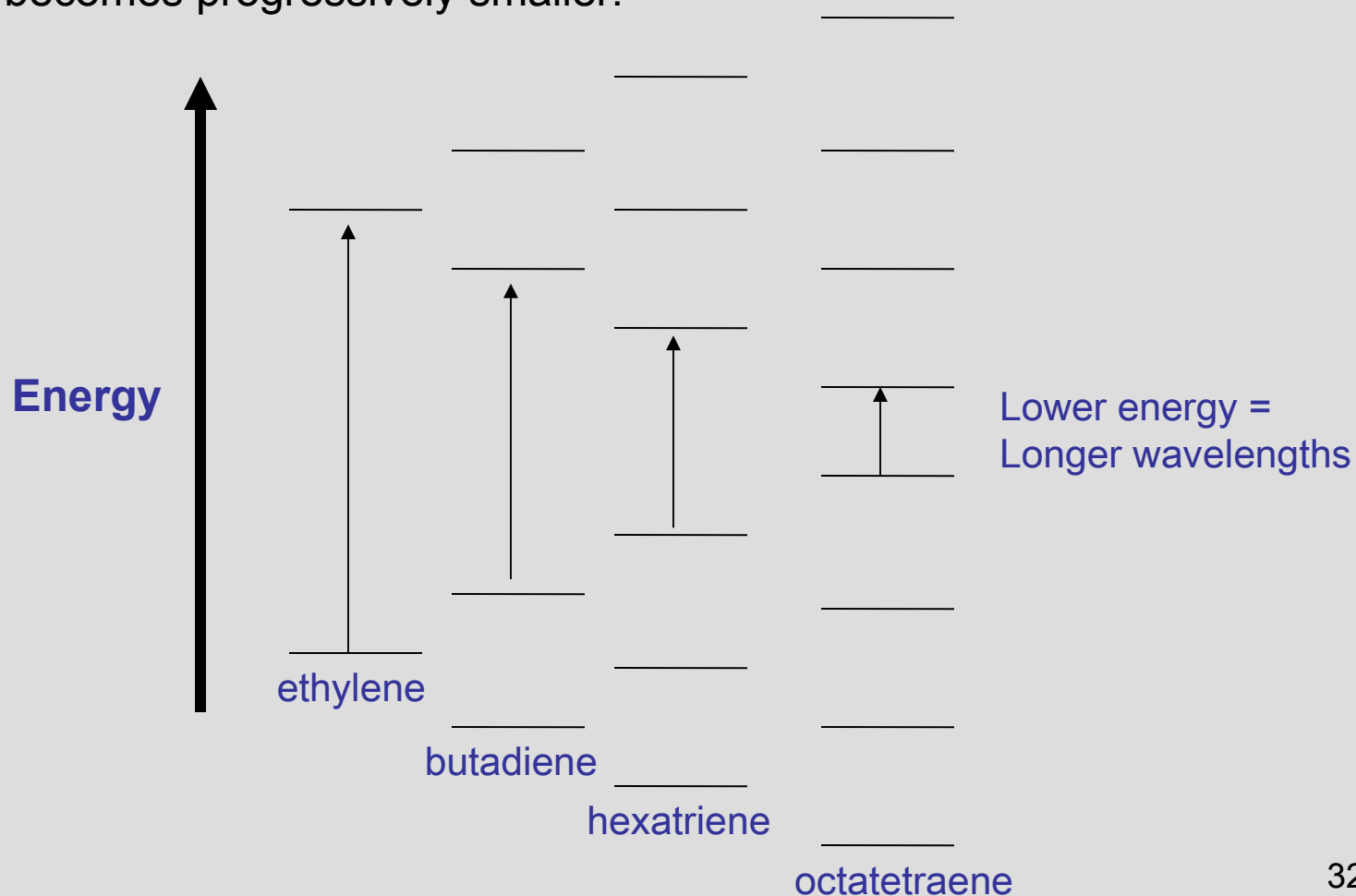

III. Chromophores

A. Substituent Effects

2. Conjugation – Alkenes

Similarly, the lone pairs of electrons on N, O, S, X can extend conjugated systems – auxochromes

Here we create 3 MOs – this interaction is not as strong as that of a conjugated π -system

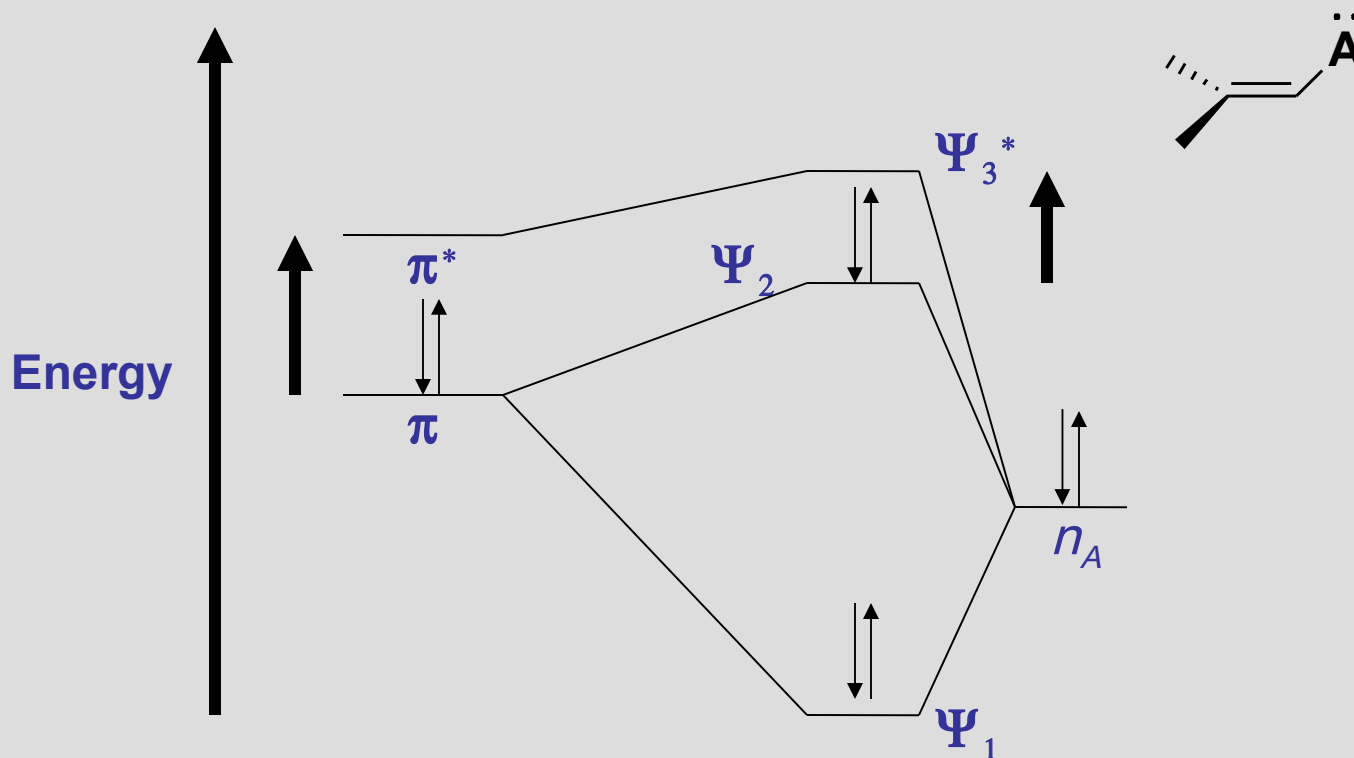

III. Chromophores

A. Substituent Effects

2. Conjugation – Alkenes

Methyl groups also cause a bathochromic shift, even though they are devoid of π - or n -electrons

This effect is thought to be through what is termed “hyperconjugation” or sigma bond resonance

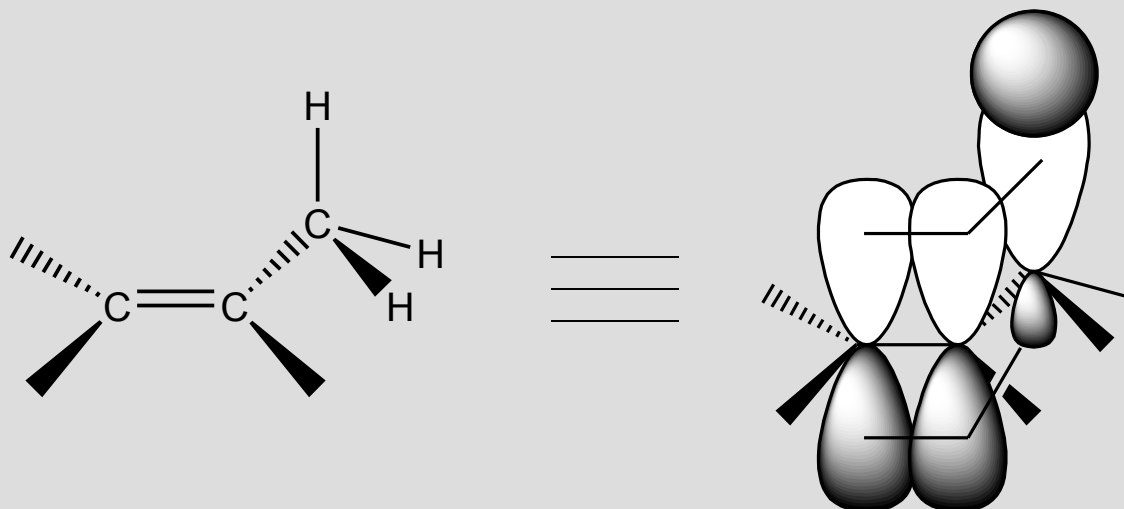

Next time – We will find that the effect of substituent groups can be reliably quantified from empirical observation of known conjugated structures and applied to new systems

This quantification is referred to as the Woodward-Fieser Rules which we will apply to three specific chromophores:

1. Conjugated dienes
2. Conjugated dienones
3. Aromatic systems

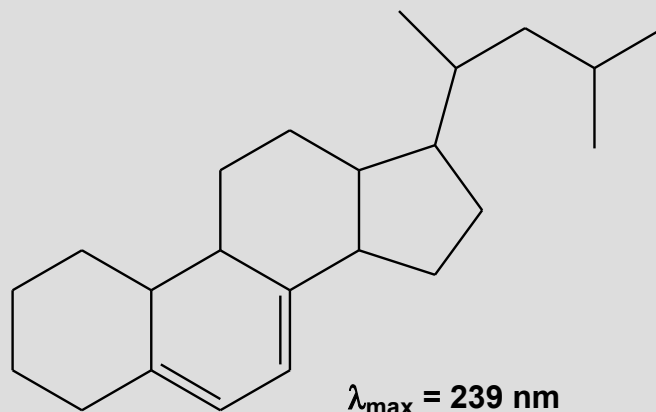

IV. Structure Determination

A. Dienes

1. General Features

For acyclic butadiene, two conformers are possible – *s-cis* and *s-trans*

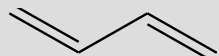

s-trans

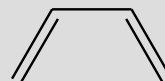

s-cis

The *s-cis* conformer is at an overall higher potential energy than the *s-trans*; therefore the HOMO electrons of the conjugated system have less of a jump to the LUMO – lower energy, longer wavelength

IV. Structure Determination

A. Dienes

1. General Features

Two possible $\pi \rightarrow \pi^*$ transitions can occur for butadiene $\Psi_2 \rightarrow \Psi_3^*$ and $\Psi_2 \rightarrow \Psi_4^*$

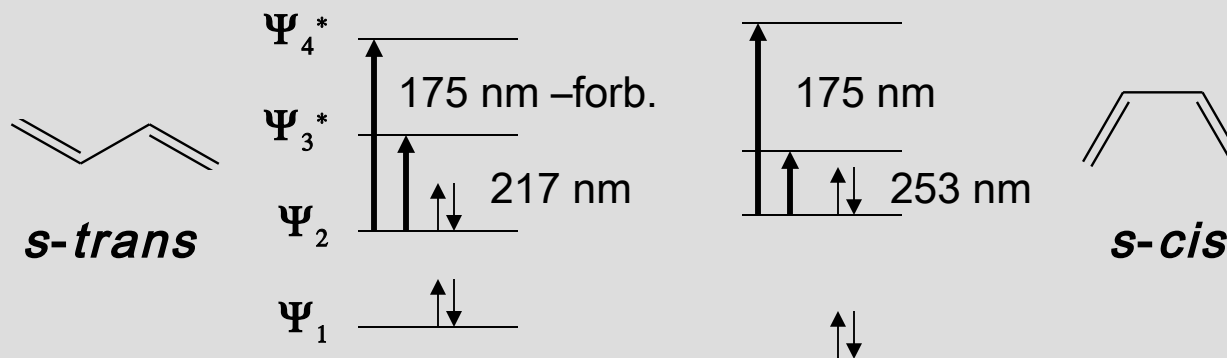

The $\Psi_2 \rightarrow \Psi_4^*$ transition is not typically observed:

- The energy of this transition places it outside the region typically observed – 175 nm
- For the more favorable *s-trans* conformation, this transition is forbidden

The $\Psi_2 \rightarrow \Psi_3^*$ transition is observed as an intense absorption

IV. Structure Determination

A. Dienes

1. General Features

The $\Psi_2 \rightarrow \Psi_3^*$ transition is observed as an intense absorption ($\epsilon = 20,000+$) based at 217 nm within the observed region of the UV

While this band is insensitive to solvent (as would be expected) it is subject to the bathochromic and hyperchromic effects of alkyl substituents as well as further conjugation

Consider:

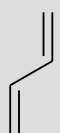

$\lambda_{\max} = 217$



253

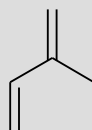

220

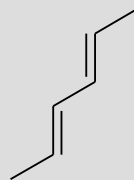

227

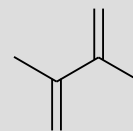

227

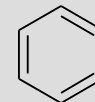

256

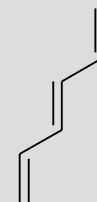

263

nm

IV. Structure Determination

A. Dienes

2. Woodward-Fieser Rules

Woodward and the Fiesers performed extensive studies of terpene and steroidal alkenes and noted similar substituents and structural features would predictably lead to an empirical prediction of the wavelength for the lowest energy $\pi \rightarrow \pi^*$ electronic transition

This work was distilled by Scott in 1964 into an extensive treatise on the Woodward-Fieser rules in combination with comprehensive tables and examples – (A.I. Scott, *Interpretation of the Ultraviolet Spectra of Natural Products*, Pergamon, NY, 1964)

A more modern interpretation was compiled by Rao in 1975 – (C.N.R. Rao, *Ultraviolet and Visible Spectroscopy*, 3rd Ed., Butterworths, London, 1975)

IV. Structure Determination

A. Dienes

2. Woodward-Fieser Rules - Dienes

The rules begin with a base value for λ_{\max} of the chromophore being observed:



acyclic butadiene = 217 nm

The incremental contribution of substituents is added to this base value from the group tables:

Group	Increment
Extended conjugation	+30
Each exo-cyclic C=C	+5
Alkyl	+5
-OCOCH ₃	+0
-OR	+6
-SR	+30
-Cl, -Br	+5
-NR ₂	+60

IV. Structure Determination

A. Dienes

2. Woodward-Fieser Rules - Dienes

For example:

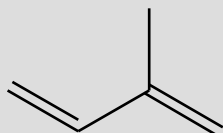

Isoprene - acyclic butadiene =	217 nm
one alkyl subs.	<u>+ 5 nm</u>
	222 nm
Experimental value	220 nm

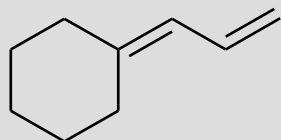

Allylidencyclohexane	
- acyclic butadiene =	217 nm
one exocyclic C=C	+ 5 nm
2 alkyl subs.	<u>+10 nm</u>
	232 nm
Experimental value	237 nm

IV. Structure Determination

A. Dienes

3. Woodward-Fieser Rules – Cyclic Dienes

There are two major types of cyclic dienes, with two different base values

Heteroannular (transoid):

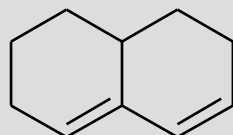

$$\epsilon = 5,000 - 15,000$$
$$\text{base } \lambda_{\text{max}} = 214$$

Homoannular (cisoid):

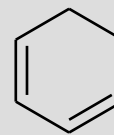

$$\epsilon = 12,000 - 28,000$$
$$\text{base } \lambda_{\text{max}} = 253$$

The increment table is the same as for acyclic butadienes with a couple additions:

Group	Increment
Additional homoannular	+39
Where both types of diene are present, the one with the longer λ becomes the base	

IV. Structure Determination

A. Dienes

3. Woodward-Fieser Rules – Cyclic Dienes

In the pre-NMR era of organic spectral determination, the power of the method for discerning isomers is readily apparent

Consider abietic vs. levopimaric acid:

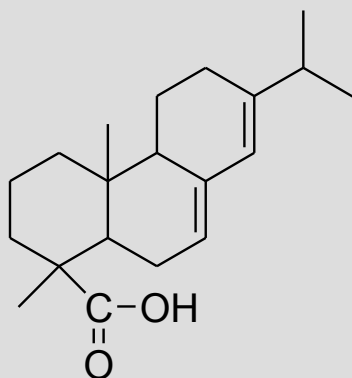

abietic acid

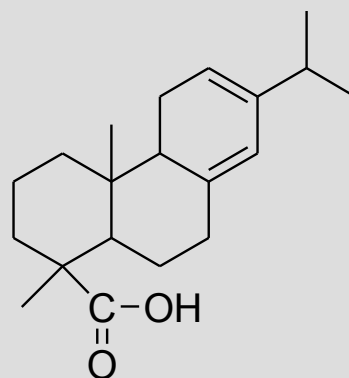

levopimaric acid

IV. Structure Determination

A. Dienes

3. Woodward-Fieser Rules – Cyclic Dienes

For example:

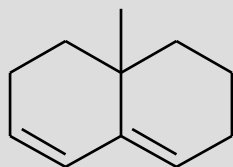

1,2,3,7,8,8a-hexahydro-8a-methylnaphthalene

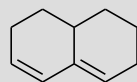

heteroannular diene = 214 nm

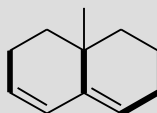

3 alkyl subs. (3 x 5) +15 nm

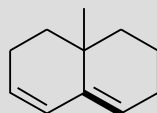

1 exo C=C + 5 nm
234 nm

Experimental value 235 nm

IV. Structure Determination

A. Dienes

3. Woodward-Fieser Rules – Cyclic Dienes

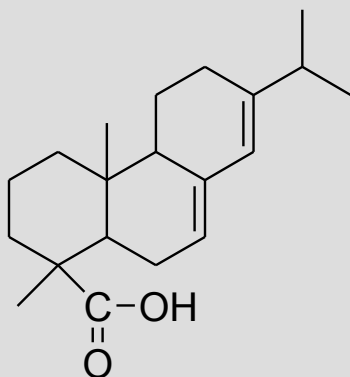

heteroannular diene = 214 nm

4 alkyl subs. (4 x 5) +20 nm

1 exo C=C + 5 nm

239 nm

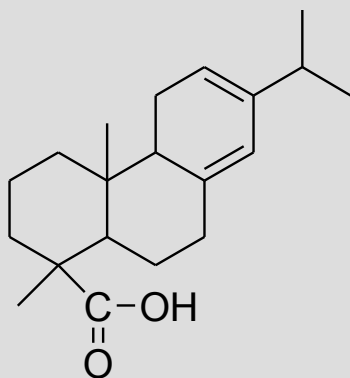

homoannular diene = 253 nm

4 alkyl subs. (4 x 5) +20 nm

1 exo C=C + 5 nm

278 nm

IV. Structure Determination

A. Dienes

3. Woodward-Fieser Rules – Cyclic Dienes

Be careful with your assignments – three common errors:

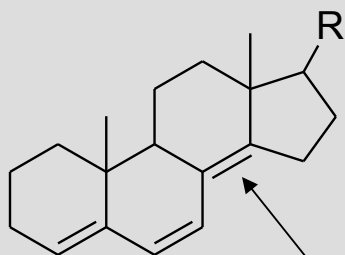

This compound has three exocyclic double bonds; the indicated bond is exocyclic to *two* rings

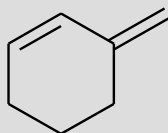

This is *not* a heteroannular diene; you would use the base value for an acyclic diene

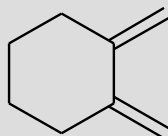

Likewise, this is *not* a homoannular diene; you would use the base value for an acyclic diene

IV. Structure Determination

B. Enones

1. General Features

Carbonyls, as we have discussed have two primary electronic transitions:

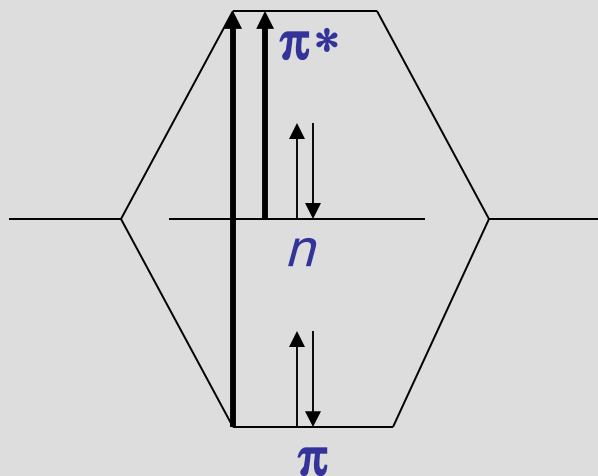

Remember, the $\pi \rightarrow \pi^*$ transition is allowed and gives a high ϵ , but lies outside the routine range of UV observation

The $n \rightarrow \pi^*$ transition is forbidden and gives a very low ϵ , but can routinely be observed

IV. Structure Determination

B. Enones

1. General Features

For auxochromic substitution on the carbonyl, pronounced hypsochromic shifts are observed for the $n \rightarrow \pi^*$ transition (λ_{\max}):



293 nm

This is explained by the inductive withdrawal of electrons by O, N or halogen from the carbonyl carbon – this causes the n -electrons on the carbonyl oxygen to be held more firmly

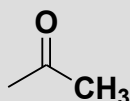

279

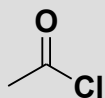

235

It is important to note this is different from the auxochromic effect on $\pi \rightarrow \pi^*$ which extends conjugation and causes a bathochromic shift

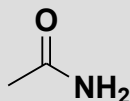

214

In most cases, this bathochromic shift is not enough to bring the $\pi \rightarrow \pi^*$ transition into the observed range

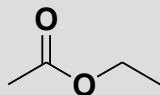

204

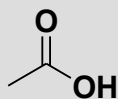

204

IV. Structure Determination

B. Enones

1. General Features

Conversely, if the C=O system is conjugated both the $n \rightarrow \pi^*$ and $\pi \rightarrow \pi^*$ bands are bathochromically shifted

Here, several effects must be noted:

- i. the effect is more pronounced for $\pi \rightarrow \pi^*$
- ii. if the conjugated chain is long enough, the much higher intensity $\pi \rightarrow \pi^*$ band will overlap and drown out the $n \rightarrow \pi^*$ band
- iii. the shift of the $n \rightarrow \pi^*$ transition is not as predictable

For these reasons, empirical Woodward-Fieser rules for conjugated enones are for the higher intensity, allowed $\pi \rightarrow \pi^*$ transition

IV. Structure Determination

B. Enones

1. General Features

These effects are apparent from the MO diagram for a conjugated enone:

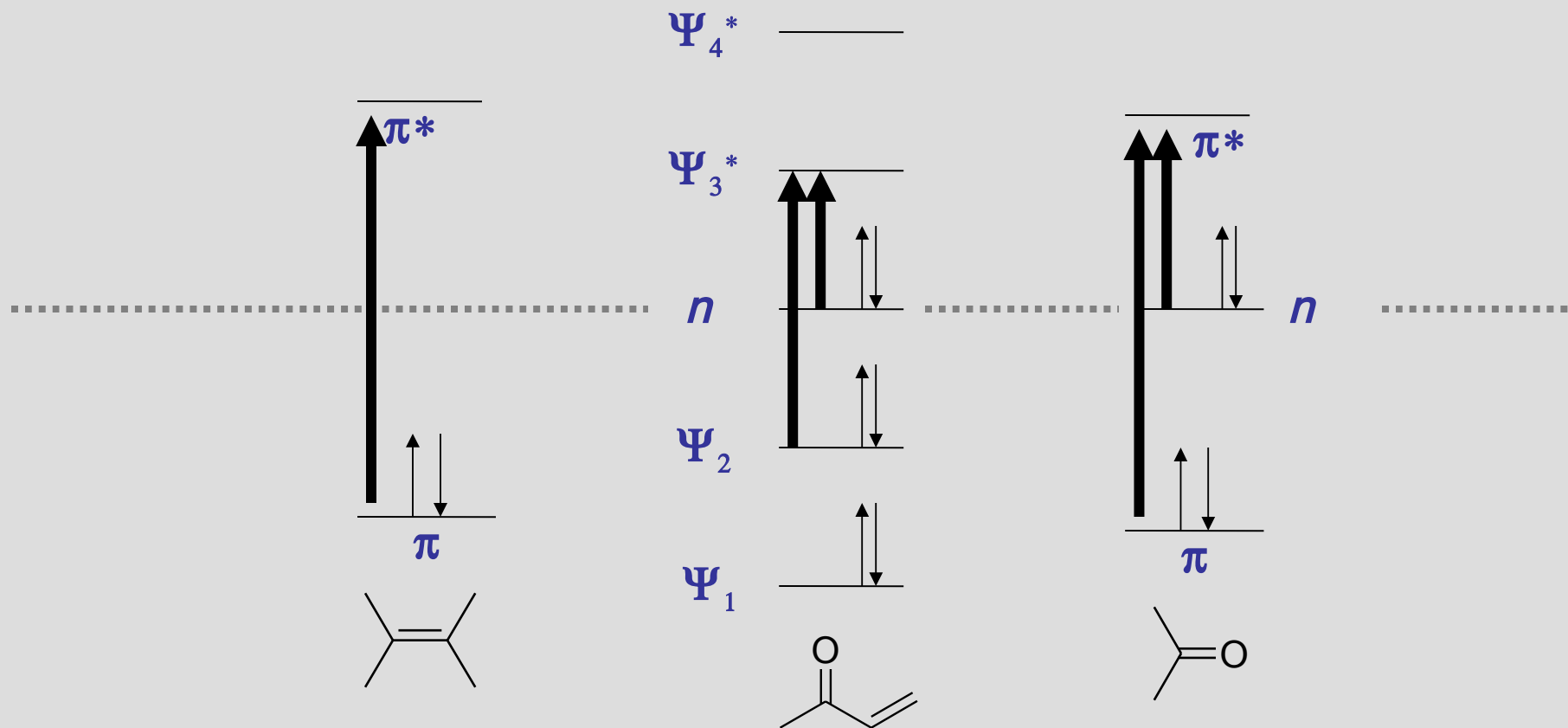

IV. Structure Determination

B. Enones

1. Woodward-Fieser Rules - Enones

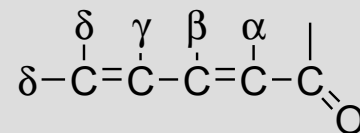
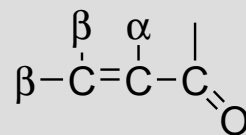

Group		Increment
6-membered ring or acyclic enone		Base 215 nm
5-membered ring parent enone		Base 202 nm
Acyclic dienone		Base 245 nm
Double bond extending conjugation		30
Alkyl group or ring residue	α, β, γ and higher	10, 12, 18
-OH	α, β, γ and higher	35, 30, 18
-OR	$\alpha, \beta, \gamma, \delta$	35, 30, 17, 31
-O(C=O)R	α, β, δ	6
-Cl	α, β	15, 12
-Br	α, β	25, 30
-NR ₂	β	95
Exocyclic double bond		5
Homocyclic diene component		39

IV. Structure Determination

B. Enones

1. Woodward-Fieser Rules - Enones

Aldehydes, esters and carboxylic acids have different base values than ketones

Unsaturated system	Base Value
Aldehyde	208
With α or β alkyl groups	220
With α,β or β,β alkyl groups	230
With α,β,β alkyl groups	242
Acid or ester	
With α or β alkyl groups	208
With α,β or β,β alkyl groups	217
Group value – exocyclic α,β double bond	+5
Group value – endocyclic α,β bond in 5 or 7 membered ring	+5

IV. Structure Determination

B. Enones

1. Woodward-Fieser Rules - Enones

Unlike conjugated alkenes, solvent does have an effect on λ_{\max}

These effects are also described by the Woodward-Fieser rules

Solvent correction	Increment
Water	+8
Ethanol, methanol	0
Chloroform	-1
Dioxane	-5
Ether	-7
Hydrocarbon	-11

IV. Structure Determination

B. Enones

1. Woodward-Fieser Rules - Enones

Some examples – keep in mind these are more complex than dienes

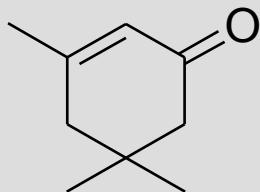

cyclic enone =	215 nm
2 x β - alkyl subs. (2 x 12)	<u>+24 nm</u>
	239 nm

Experimental value	238 nm
--------------------	--------

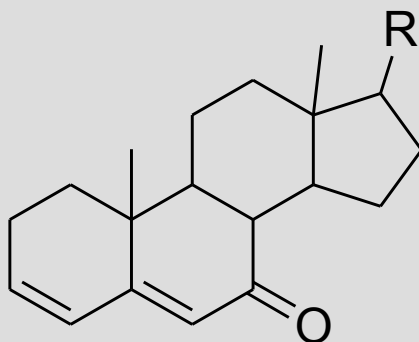

cyclic enone =	215 nm
extended conj.	+30 nm
β -ring residue	+12 nm
δ -ring residue	+18 nm
exocyclic double bond	<u>+ 5 nm</u>
	280 nm

Experimental	280 nm
--------------	--------

IV. Structure Determination

B. Enones

1. Woodward-Fieser Rules - Enones

Take home problem – can these two isomers be discerned by UV-spec

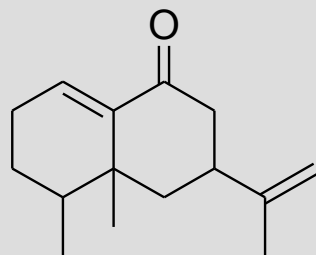

Eremophilone

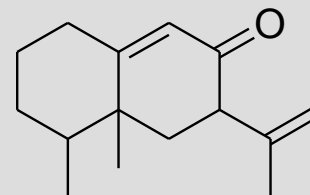

allo-Eremophilone

Problem Set 1: (text) – 1,2,3a,b,c,d,e,f,j, 4, 5, 6 (1st, 2nd and 5th pairs), 8a, b, c

Problem Set 2: outside problems/key -Tuesday

IV. Structure Determination

C. Aromatic Compounds

1. General Features

Although aromatic rings are among the most widely studied and observed chromophores, the absorptions that arise from the various electronic transitions are complex

On first inspection, benzene has six π -MOs, 3 filled π , 3 unfilled π^*

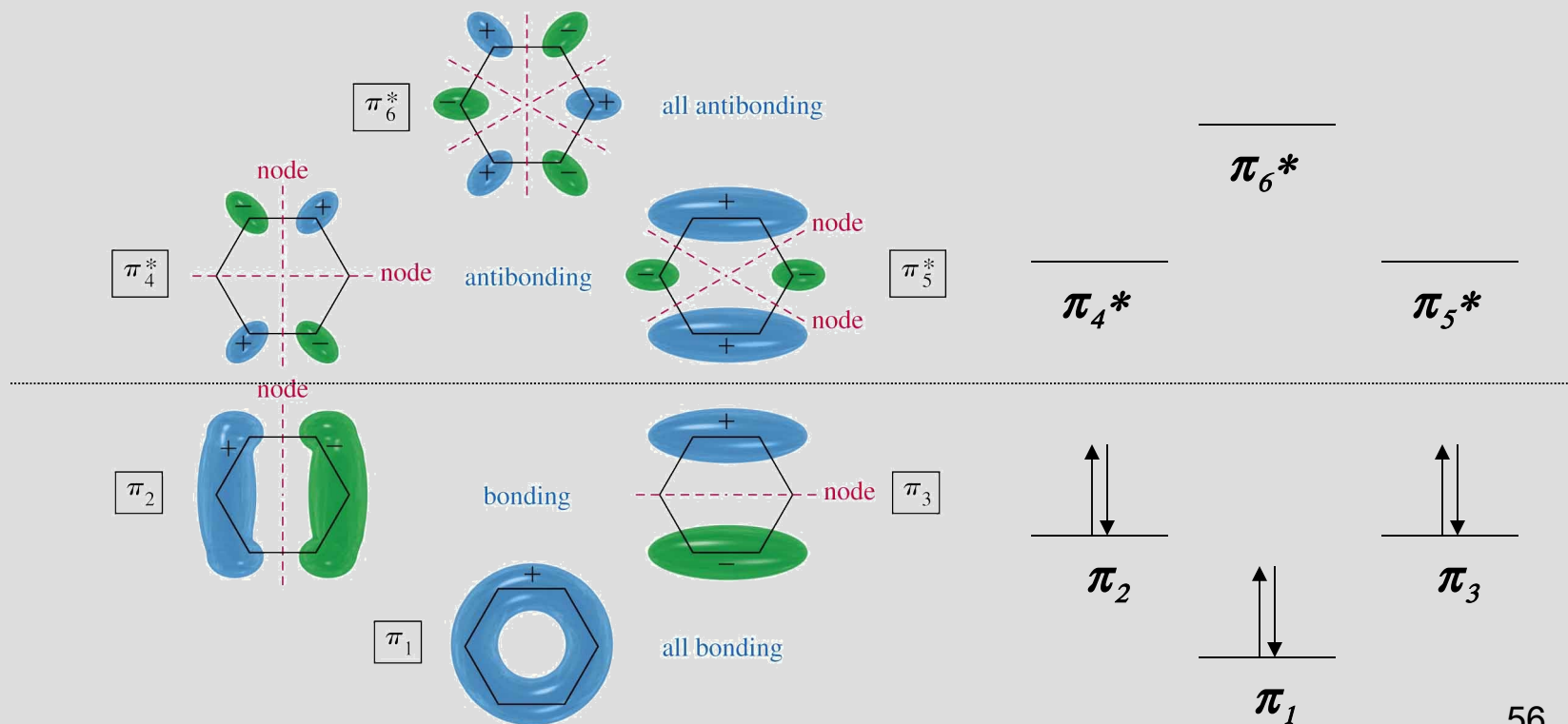

IV. Structure Determination

C. Aromatic Compounds

1. General Features

One would expect there to be four possible HOMO-LUMO $\pi \rightarrow \pi^*$ transitions at observable wavelengths (conjugation)

Due to symmetry concerns and selection rules, the actual transition energy states of benzene are illustrated at the right:

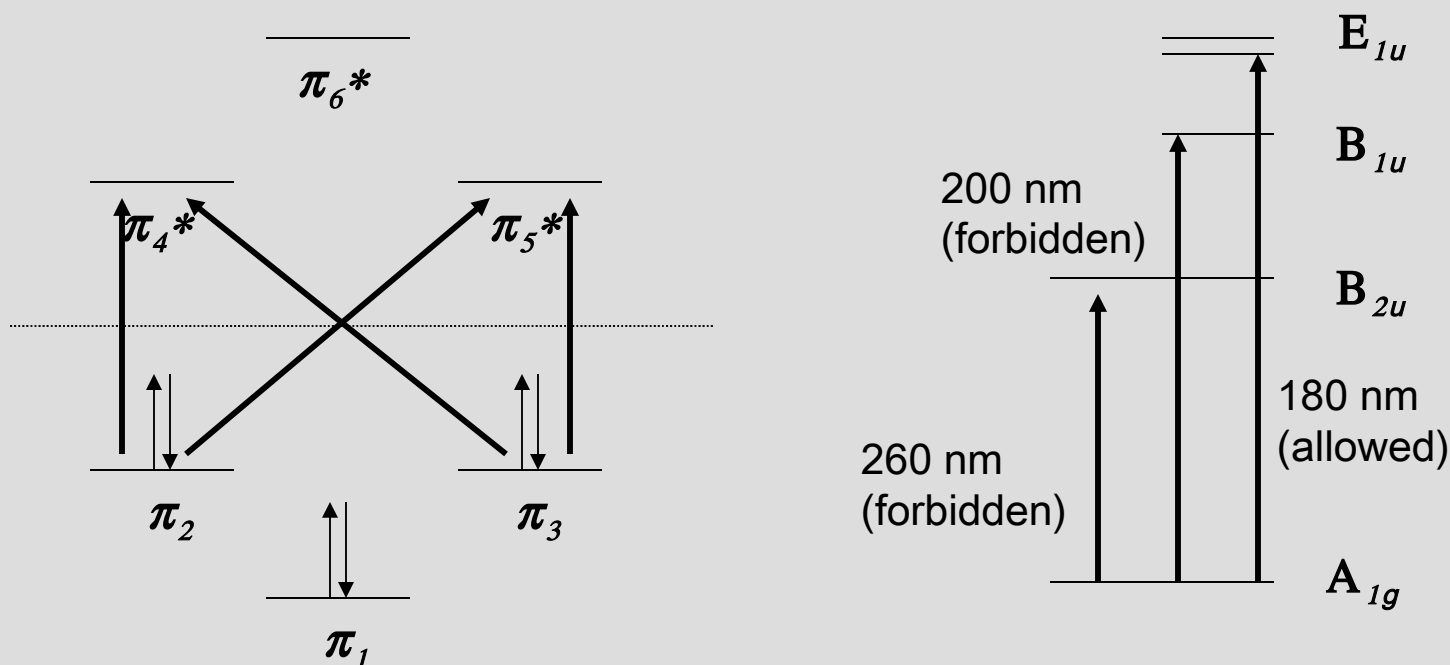

IV. Structure Determination

C. Aromatic Compounds

1. General Features

The allowed transition ($\epsilon = 47,000$) is not in the routine range of UV obs. at 180 nm, and is referred to as the *primary band*

The forbidden transition ($\epsilon = 7400$) is observed if substituent effects shift it into the obs. region; this is referred to as the *second primary band*

At 260 nm is another forbidden transition ($\epsilon = 230$), referred to as the *secondary band*.

This transition is fleetingly allowed due to the disruption of symmetry by the vibrational energy states, the overlap of which is observed in what is called *fine structure*

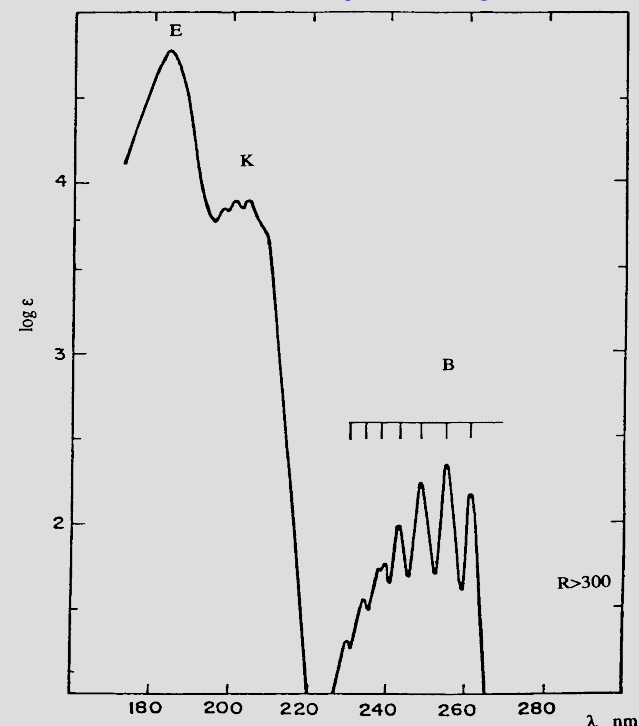

IV. Structure Determination

C. Aromatic Compounds

1. General Features

Substitution, auxochromic, conjugation and solvent effects can cause shifts in wavelength and intensity of aromatic systems similar to dienes and enones

However, these shifts are difficult to predict – the formulation of empirical rules is for the most part is not efficient (there are more exceptions than rules)

There are some general qualitative observations that can be made by classifying substituent groups --

IV. Structure Determination

C. Aromatic Compounds

2. Substituent Effects

a. Substituents with Unshared Electrons

- If the group attached to the ring bears n electrons, they can induce a shift in the primary and secondary absorption bands
- Non-bonding electrons extend the π -system through resonance – lowering the energy of transition $\pi \rightarrow \pi^*$
- More available n -pairs of electrons give greater shifts

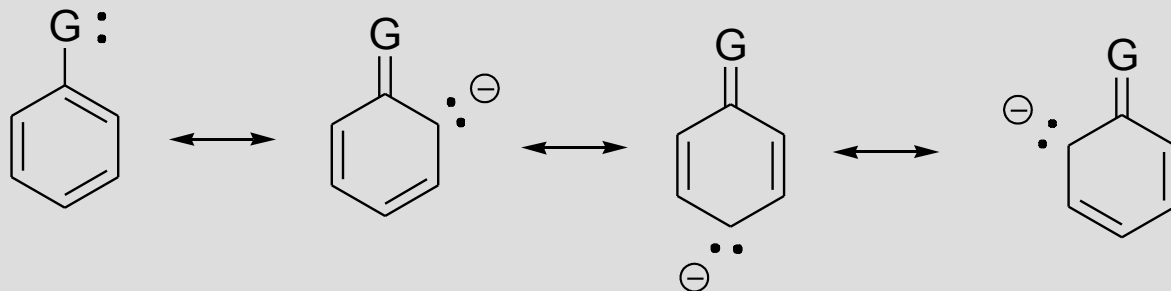

IV. Structure Determination

C. Aromatic Compounds

2. Substituent Effects

a. Substituents with Unshared Electrons

- The presence of n -electrons gives the possibility of $n \rightarrow \pi^*$ transitions
- If this occurs, the electron now removed from G, becomes an extra electron in the anti-bonding π^* orbital of the ring
- This state is referred to as a *charge-transfer excited state*

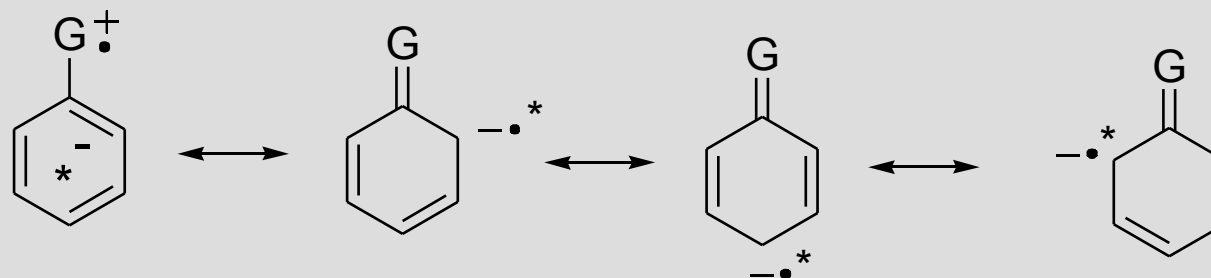

IV. Structure Determination

C. Aromatic Compounds

2. Substituent Effects

a. Substituents with Unshared Electrons

- pH can change the nature of the substituent group
- deprotonation of oxygen gives more available n -pairs, *lowering* transition energy
- protonation of nitrogen eliminates the n -pair, *raising* transition energy

Substituent	Primary		Secondary	
	λ_{\max}	ϵ	λ_{\max}	ϵ
-H	203.5	7,400	254	204
-OH	211	6,200	270	1,450
-O ⁻	235	9,400	287	2,600
-NH ₂	230	8,600	280	1,430
-NH ₃ ⁺	203	7,500	254	169
-C(O)OH	230	11,600	273	970
-C(O)O ⁻	224	8,700	268	560

IV. Structure Determination

C. Aromatic Compounds

2. Substituent Effects

a. Substituents Capable of π -conjugation

- When the substituent is a π -chromophore, it can interact with the benzene π -system
- With benzoic acids, this causes an appreciable shift in the primary and secondary bands
- For the benzoate ion, the effect of extra n -electrons from the anion reduces the effect slightly

Substituent	Primary		Secondary	
	λ_{\max}	ϵ	λ_{\max}	ϵ
-C(O)OH	230	11,600	273	970
-C(O)O ⁻	224	8,700	268	560

IV. Structure Determination

C. Aromatic Compounds

2. Substituent Effects

- c. Electron-donating and electron-withdrawing effects
 - No matter what electronic influence a group exerts, the presence shifts the primary absorption band to longer λ
 - Electron-withdrawing groups exert no influence on the position of the secondary absorption band
 - Electron-donating groups increase the λ and ϵ of the secondary absorption band

IV. Structure Determination

C. Aromatic Compounds

2. Substituent Effects

c. Electron-donating and electron-withdrawing effects

	Substituent	<i>Primary</i>		<i>Secondary</i>	
		λ_{\max}	ϵ	λ_{\max}	ϵ
Electron donating	-H	203.5	7,400	254	204
	-CH ₃	207	7,000	261	225
	-Cl	210	7,400	264	190
	-Br	210	7,900	261	192
	-OH	211	6,200	270	1,450
	-OCH ₃	217	6,400	269	1,480
Electron withdrawing	-NH ₂	230	8,600	280	1,430
	-CN	224	13,000	271	1,000
	C(O)OH	230	11,600	273	970
	-C(O)H	250	11,400		
	-C(O)CH ₃	224	9,800		
	-NO ₂	269	7,800		

IV. Structure Determination

C. Aromatic Compounds

2. Substituent Effects

d. Di-substituted and multiple group effects

- With di-substituted aromatics, it is necessary to consider both groups
- If both groups are electron donating or withdrawing, the effect is similar to the effect of the stronger of the two groups as if it were a *mono*-substituted ring
- If one group is electron withdrawing and one group electron donating and they are *para*- to one another, the magnitude of the shift is greater than the sum of both the group effects
- Consider *p*-nitroaniline:

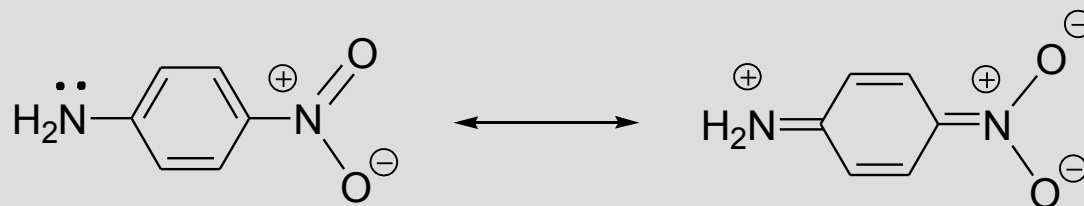

IV. Structure Determination

C. Aromatic Compounds

2. Substituent Effects

d. Di-substituted and multiple group effects

- If the two electronically dissimilar groups are ortho- or meta- to one another, the effect is usually the sum of the two individual effects (*meta*- no resonance; *ortho*-steric hind.)
- For the case of substituted benzoyl derivatives, an empirical correlation of structure with observed λ_{\max} has been developed
- This is slightly less accurate than the Woodward-Fieser rules, but can usually predict within an error of 5 nm

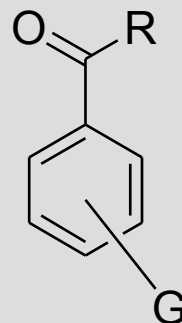

IV. Structure Determination

C. Aromatic Compounds

2. Substituent Effects

d. Di-substituted and multiple group effects

Parent Chromophore	λ_{\max}
R = alkyl or ring residue	246
R = H	250
R = OH or O-Alkyl	230

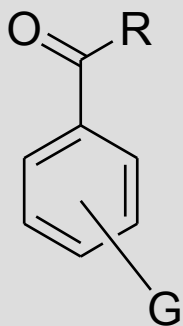

Substituent	Substituent increment		
	<i>o</i>	<i>m</i>	<i>p</i>
G			
Alkyl or ring residue	3	3	10
-O-Alkyl, -OH, -O-Ring	7	7	25
-O-	11	20	78
-Cl	0	0	10
-Br	2	2	15
-NH ₂	13	13	58
-NHC(O)CH ₃	20	20	45
-NHCH ₃			73
-N(CH ₃) ₂	20	20	85

IV. Structure Determination

C. Aromatic Compounds

2. Substituent Effects

d. Polynuclear aromatics

- When the number of fused aromatic rings increases, the λ for the primary and secondary bands also increase

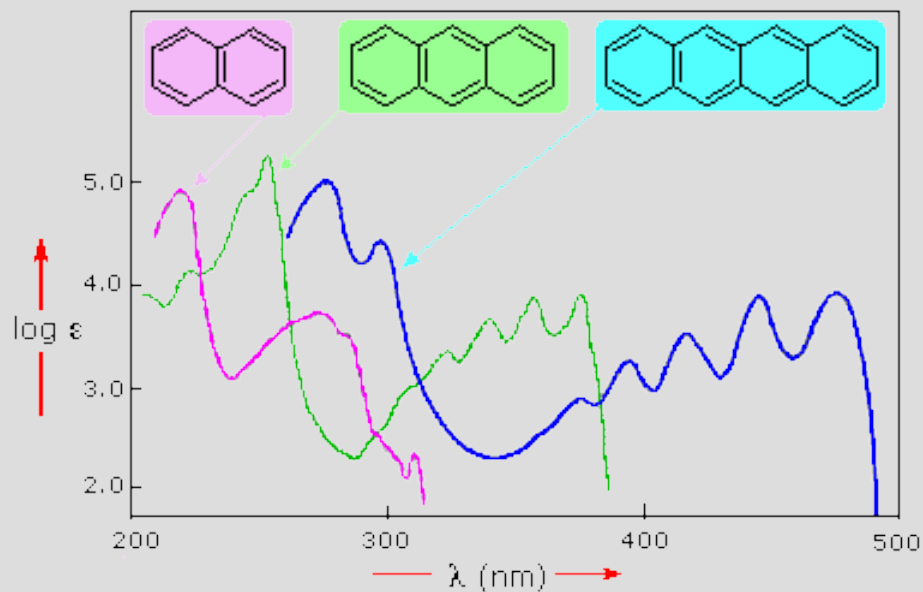

- For heteroaromatic systems spectra become complex with the addition of the $n \rightarrow \pi^*$ transition and ring size effects, and are unique to each case

UV Spectroscopy

V. Visible Spectroscopy

A. Color

1. General

- The portion of the EM spectrum from 400-800 is observable to humans- we (and some other mammals) have the adaptation of seeing color at the expense of greater detail

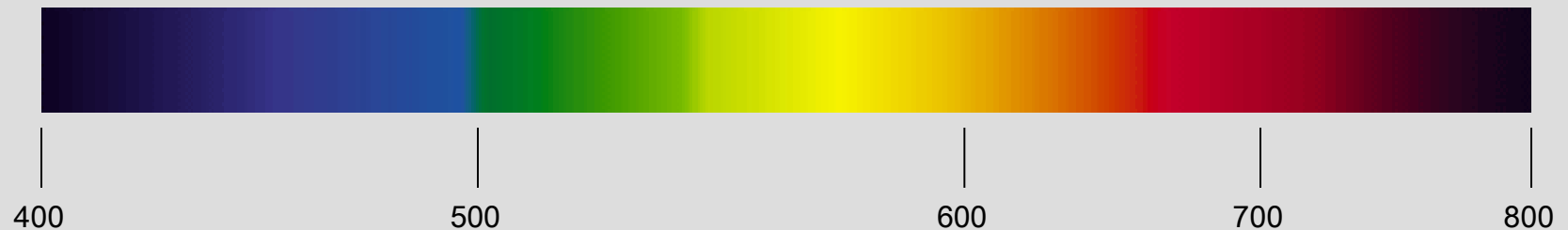

λ , nm

Violet	400-420
Indigo	420-440
Blue	440-490
Green	490-570
Yellow	570-585
Orange	585-620
Red	620-780

V. Visible Spectroscopy

A. Color

1. General

- When white (continuum of λ) light passes through, or is reflected by a surface, those λ s that are absorbed are removed from the transmitted or reflected light respectively
- What is “seen” is the complimentary colors (those that are not absorbed)
- This is the origin of the “color wheel”

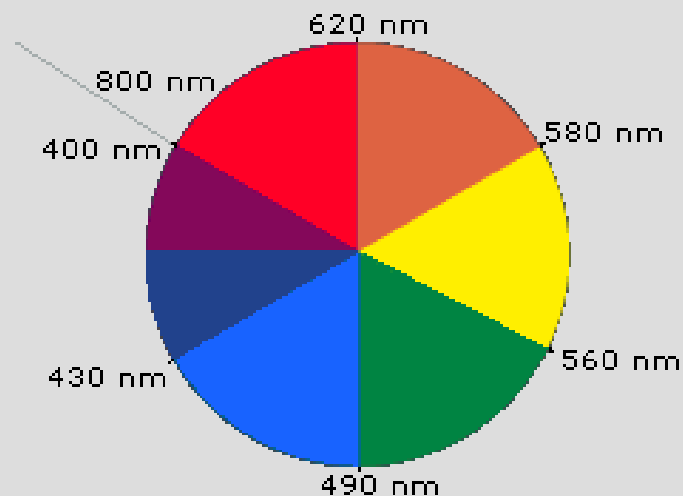

V. Visible Spectroscopy

A. Color

1. General

- Organic compounds that are “colored” are typically those with extensively conjugated systems (typically more than five)
- Consider β -carotene

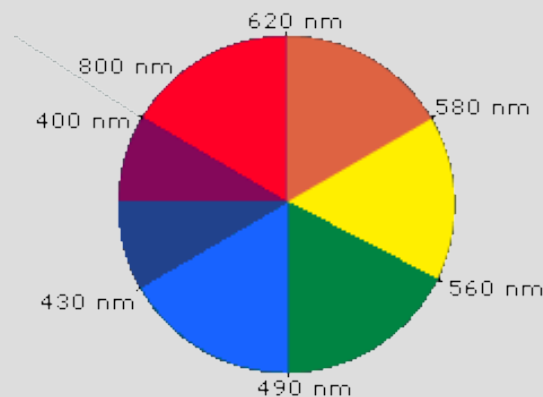
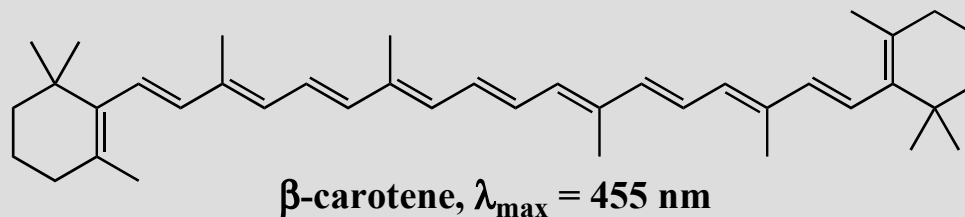

λ_{\max} is at 455 – in the far blue region of the spectrum – this is absorbed

The remaining light has the complementary color of orange

UV Spectroscopy

V. Visible Spectroscopy

A. Color

1. General

- Likewise:

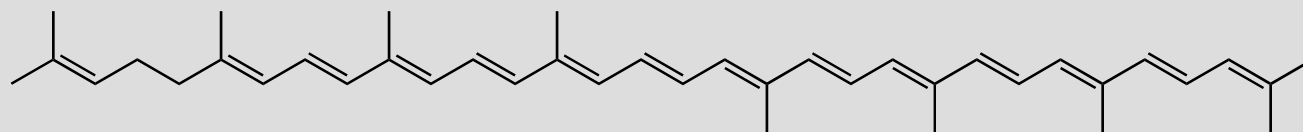

lycopene, $\lambda_{\max} = 474 \text{ nm}$

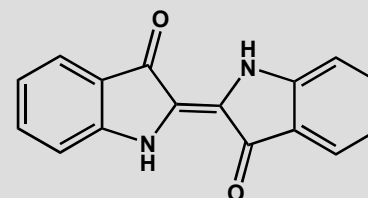

indigo

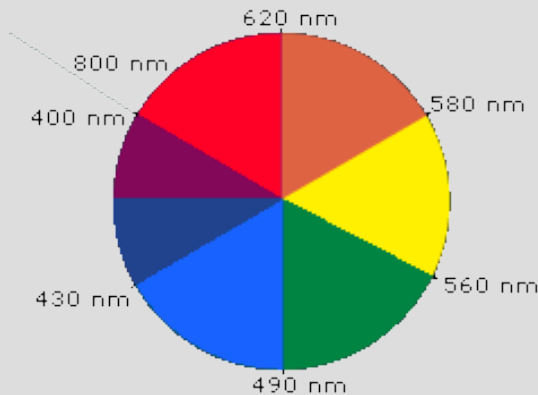

λ_{\max} for lycopene is at 474 – in the near blue region of the spectrum – this is absorbed, the compliment is now red

λ_{\max} for indigo is at 602 – in the orange region of the spectrum – this is absorbed, the compliment is now indigo!

V. Visible Spectroscopy

A. Color

1. General

- One of the most common class of colored organic molecules are the azo dyes:

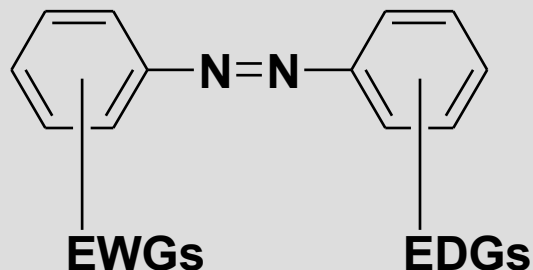

From our discussion of di-substituted aromatic chromophores, the effect of opposite groups is greater than the sum of the individual effects – more so on this heavily conjugated system

Coincidentally, it is necessary for these to be opposite for the original synthetic preparation!

UV Spectroscopy

V. Visible Spectroscopy

A. Color

1. General

- These materials are some of the more familiar colors of our “environment”

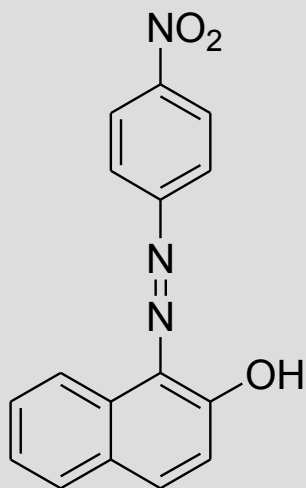

Para Red

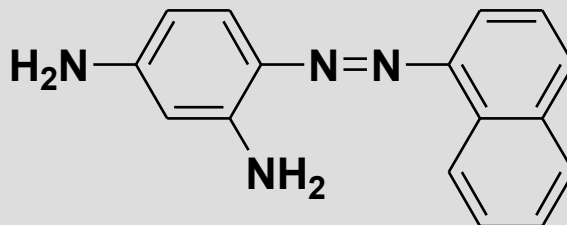

Fast Brown

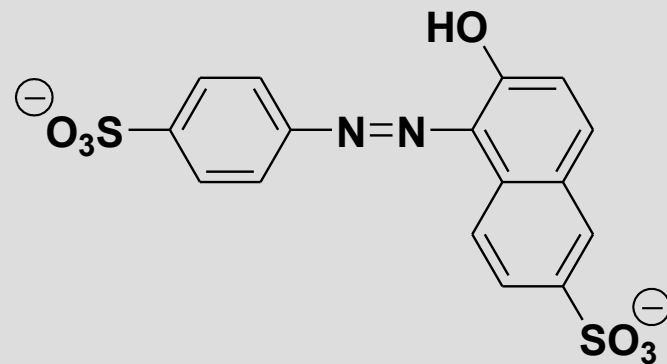

Sunset Yellow (Food Yellow 3)



The colors of M&M's

Bright Blue

Common Food Uses

Beverages, dairy products, powders, jellies, confections, condiments, icing.

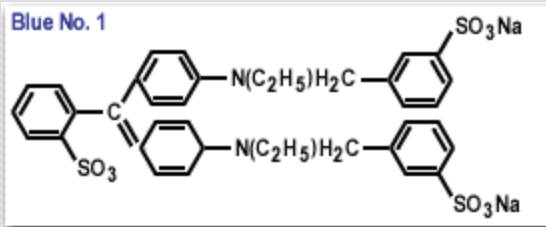

Orange-red

Common Food Uses

Gelatins, puddings, dairy products, confections, beverages, condiments.

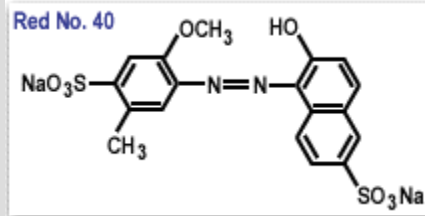

Orange

Common Food Uses

Cereals, baked goods, snack foods, ice-cream, beverages, dessert powders, confections

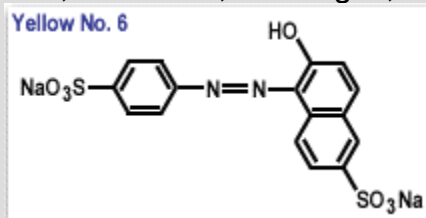

Royal Blue

Common Food Uses

Baked goods, cereals, snack foods, ice-cream, confections, cherries.

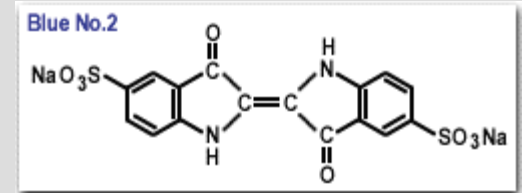

Lemon-yellow

Common Food Uses

Custards, beverages, ice-cream, confections, preserves, cereals.

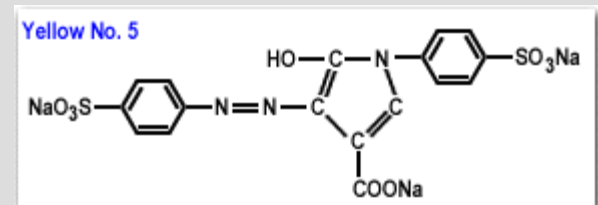

V. Visible Spectroscopy

A. Color

1. General

- In the biological sciences these compounds are used as dyes to selectively stain different tissues or cell structures
- **Biebrich Scarlet** - Used with picric acid/aniline blue for staining collagen, reticulum, muscle, and plasma. Luna's method for erythrocytes & eosinophil granules. Guard's method for sex chromatin and nuclear chromatin.

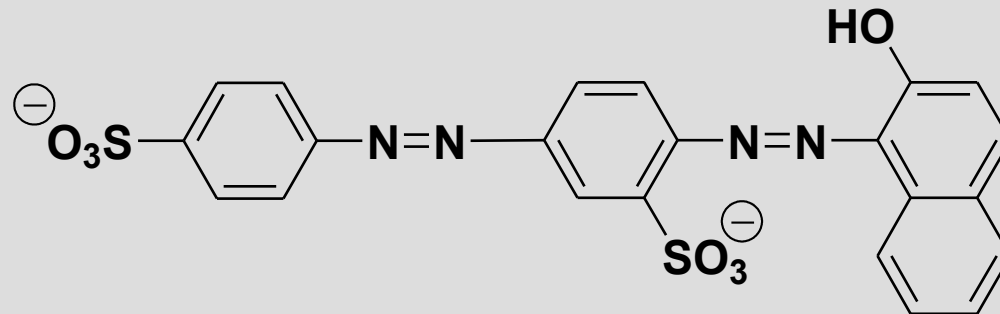

UV Spectroscopy

V. Visible Spectroscopy

A. Color

1. General

- In the chemical sciences these are the acid-base indicators used for the various pH ranges:
- Remember the effects of pH on aromatic substituents

Methyl Orange

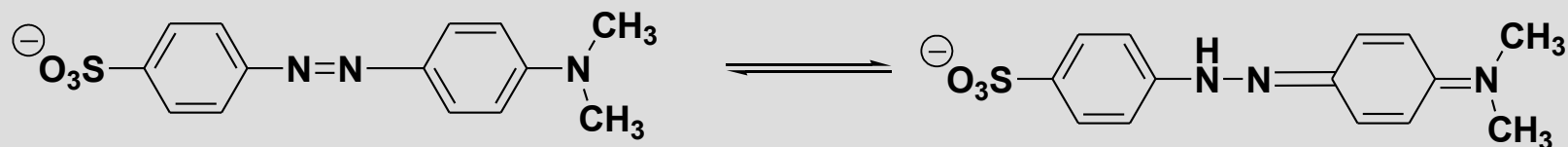

Yellow, pH > 4.4

Red, pH < 3.2

